

SEYMOUR®

A MIDWEST RAKE COMPANY

SUPERIOR HEAVY-DUTY TOOLS
STRUCTRON

LINK HANDLES

HOME & HARDWARE

BROOMS & SQUEEGEES

SNOW TOOLS & SCRAPERS

INDUSTRIAL / CONTRACTOR SUPPLY

STRIKING TOOLS & BARS

LANDSCAPE & AGRICULTURE

CUTTING & PRUNING TOOLS

FIRE STARTER & FIREPLACE

LINK REPLACEMENT HANDLES

MERCHANDISING



SINCE 1872

**SEYMOUR
COMBINED
CATALOGS**

Quality Tools Since 1872

Back in 1872 Seymour Manufacturing was a premier manufacturer of wagon wheels and hubs. In the late 1800's they adapted to meet the growing demand for scythes with grain cradles.

The wagon wheel business is gone and scythes are rare, but Seymour is stronger than ever building quality hand tools for a wide range of home, farm, commercial, and industrial applications.

Seymour and Structron brand tools

Realizing that many future tools would have fiberglass handles, Seymour Manufacturing acquired Structron brand tools in 1995. Strength tests prove that these premium quality fiberglass handle tools are the strongest on the market.

Pioneering in both hardwood and fiberglass handle tools has made "Quality Tools Since 1872" and "First in Fiberglass" more than just clever slogans. They represent our commitment to continue to push the boundaries of technology in products, manufacturing, and customer service.

GOOD-BETTER-BEST product families

Seymour provides three basic quality levels in both fiberglass and hardwood handle tools. All are designed to provide the end-user with the best overall value at each quality level. We do this by carefully matching the design components with the demands and frequency of use of the intended applications.

Fiberglass handle tool families

- STRUCTRON® best quality
- PROFESSIONAL better quality
- DuraLite™ good quality

Wood handle tool families

- INDUSTRIAL best quality
- PROFESSIONAL better quality
- VALUE*PLUS™ good quality

Seymour striking tools and replacement handles

In addition to lawn and garden tools, Seymour has a complete line of striking tools and a complete line of replacement handles.

Seymour striking tools include drilling, cross peen, engineers, and sledge hammers; axes, splitting mauls, and wedges; picks and mattocks; and bars, tampers, and SuperScraper™ scraping tools.

The Link Handle Division makes replacement handles for striking tools such as axes, sledges, picks, and hammers as well as agricultural tools such as shovels, rakes, and hoes. These replacement handles are made from American hickory, American ash, other hardwoods, and fiberglass.



Table of Contents

- Structron® - First in Fiberglass 4-5
- Agricultural “Specialty” 42, 49-53
- Brooms & Squeegees 25
- Contractor “Specialty”, Roofing, Concrete, Asphalt, Stoning, etc. 28, 29
- Cutting Tools, Pruners, & Saws 45-51
- Extension Handles 24
- Fencing 39
- Fire Starter 54-55
- Fireplace & Log Accessories 56-66
- Forks 41
- Hoes & Cultivators 6, 10-15, 28, 42-43
- Lady Floral® & Hand Tools 18-19
- Landscaping “Specialty” 43, 48-49
- LINK® [Replacement Handles]. 68-89
- Merchandising Displays, Fixtures, & Aides . . 67, 90-94
- Post Hole Diggers & Augers 20-23
- Rakes 6, 10-15, 28-29, 39, 44
- Scoops 40
- Scrapers & Tampers 38
- Shovels
 - Fiberglass Handled 6-7, 8, 10-11, 16-17
 - Wood Handled 9, 12-17
 - Forged Head 8-9
 - Trenching & Cleanout 17
 - Specialty 16
 - Super Shovel® 16
 - Structron®  6, 7, 8
 - 10 Series “Value Plus” 14
 - 20 Series “Professional” 13
 - 30 Series “Industrial” 12
 - 40 Series “Professional” 10
 - 80 Series “DuraLite®” 11
 - 90 Series “Promotional” 15
- Striking Tools [Hammers, Axes, Picks & Mattocks, Mauls, Wedges, and Bars] 31-38
- Wheelbarrows 30
- History of Seymour® 96



FIRST IN FIBERGLASS

Since 1979 Structron® brand products have lead the industry in fiberglass handle tools. The first Structron tool, the Superhandle® extension handle, pioneered the use of fiberglass strands and continuous strand mats to produce lightweight, extra-strong tubular handles. This technology lead to Structron brand tools, the first-ever line of premium quality, high performance fiberglass construction, landscaping, and gardening tools.



Extra-large D-grip handle

Designed to offer more room for gloved hands, the solid polypropylene grip is light weight yet durable. Resists heat and cold. Held in place with a steel rivet.

FIRST IN QUALITY

Structron brand tools were the first to incorporate a solid fiberglass compression rod, the PowerCore™, in the tool handle for extra strength. We were also the first to use an extra-large steel connecting ferrule, the exclusive PermaGrip® steel collar for greater durability. And Structron tools were the first to use the ProGrip™ comfort grip for better grip and added comfort.

PowerCore™ solid fiberglass reinforcing rod

Extends 12.5 inches from the handle into the shank and blade for maximum strength at this critical stress point.

Highest quality tool head

Spring steel blade flexes but won't bend or break as easily as other shovel blades. Extra-sharp, heat-treated, high-carbon stamped steel head provides the ultimate in durability. Wears better. Lasts longer.

PermaGrip® steel collar

A rivetless ring of steel that connects the shovel neck, handle, and fiberglass PowerCore™ rod, making it one solid unit.

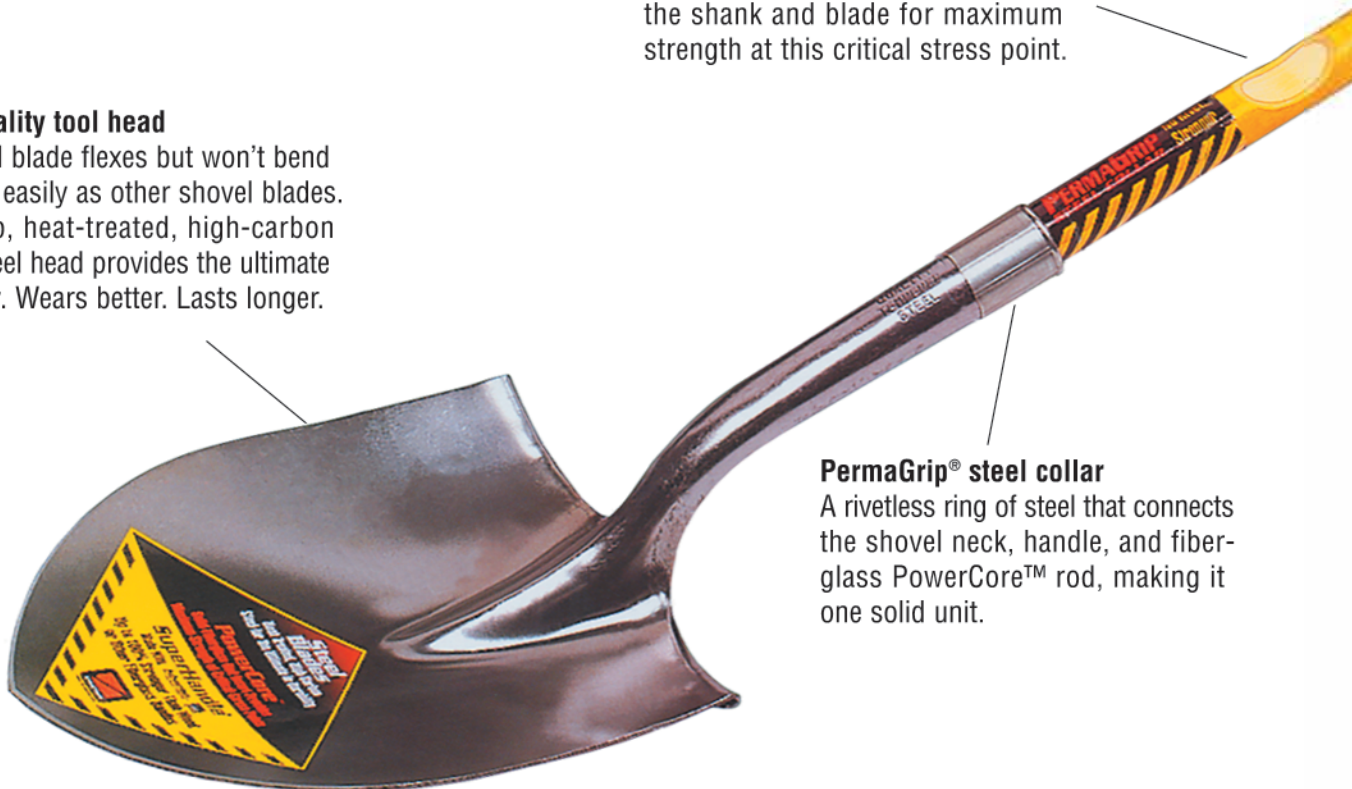

SEYMOUR

SUPERIOR HEAVY-DUTY TOOLS

STRUCTRON

ProGrip™ comfort grip

Made of durable textured vinyl with a non-slip surface for a secure grip with excellent shock absorbing protection. Unique double-wall construction for greater durability. The outer cushion is firmly attached to the vinyl inner liner to prevent movement and tearing of the cushion grip. Weather resistant.

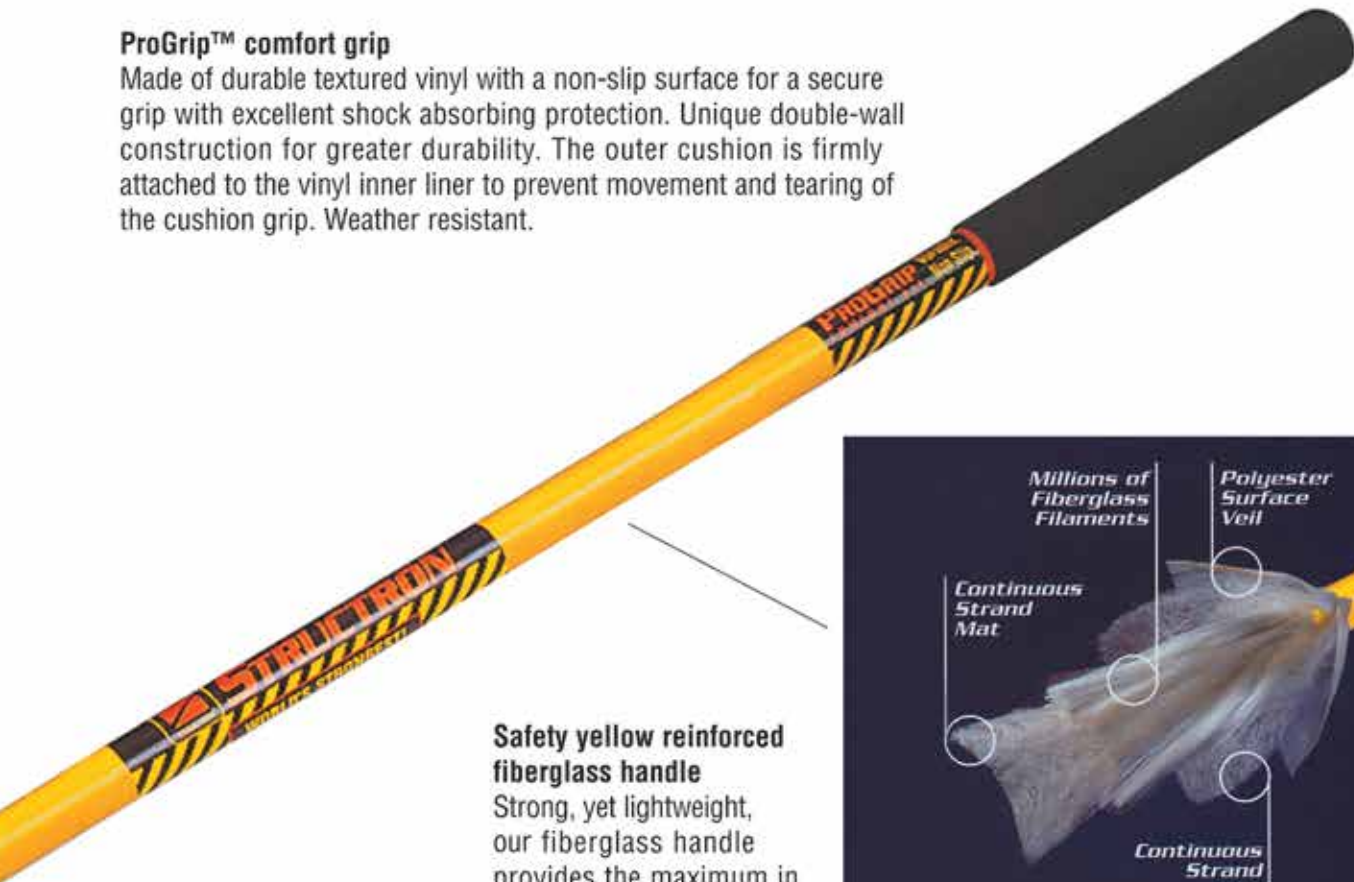

Safety yellow reinforced fiberglass handle
Strong, yet lightweight, our fiberglass handle provides the maximum in durability and visual impact.

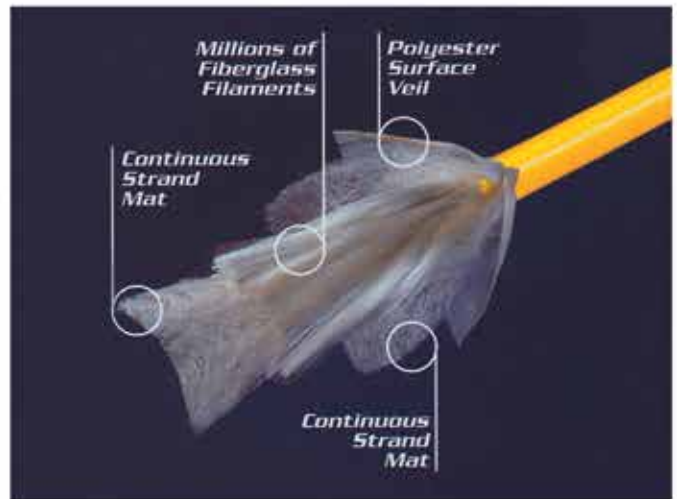

FIRST IN TECHNOLOGY

We continually test our products and improve our technology to ensure that Seymour and Structron brand tools are the strongest available at each price point and quality level. State-of-the art

manufacturing methods keep production costs as low as possible. And when combined with quality component parts, Seymour customers receive the best tool value money can buy.



TOOL BRAND	POUNDS TO FAILURE	MODE OF FAILURE
Structron	250	Head
Brand A	200	Head
Brand B	193	Head
Brand C	108	Handle
Brand D	216	Head

In this actual test, the Structron shovel was 25% stronger than Brand A, 29% stronger than Brand B, 131% stronger than Brand C, and 16% stronger than Brand D.



STRUCTRON® brand fiberglass handle tools

The most rugged fiberglass handle tools available for maximum duty construction, industrial, and commercial applications.

Structron brand 700 series shovels and spades feature heat-treated, high-carbon polished steel or forged blades for the ultimate in durability.

Structron brand 600 series shovels and spades feature tempered, heavy-duty 14 gauge blades finished with a protective coating.

The 700 and 600 series tools both use the same extra-strong Structron fiberglass handles.

14 gauge shovel heads

Spring steel shovel blades flex but won't break as easily as other shovel heads. Wears better and lasts longer.

Closed back shovel heads have welded back plates to prevent material build-up. These plates also provide extra strength.



PowerCore™ solid fiberglass reinforcing rod extends 12.5 inches from the handle into the shank and blade for maximum strength at this critical stress point.



Forged rake and hoe heads provide the added strength needed for maximum duty applications.

Photo No.	Model	Quality Level	Description	Head	Head size	Socket	Collar	Handle	Grip	UPC 0-36723 +	Pack Qty.	Pack Wgt.	Pack Cube
1	S700	Best	Round point shovel	#2 rear roll step	9" x 12"	Square	PermaGrip®	48" fiberglass	Cushion	00700 2	4	18.8	3.60
2	S712	Best	Closed back round pt	#2 front turn step	8.8" x 11.2"	Square	PermaGrip®	48" fiberglass	Cushion	50712 0	4	16.0	3.50
3	S701	Best	Square point shovel	#2 rear roll step	9.5" x 11.5"	Square	PermaGrip®	48" fiberglass	Cushion	00701 9	4	20.4	3.54
4	S600	Best	Round point shovel	#2 front turn step	9" x 11.5"	Square	PermaGrip®	48" fiberglass	Cushion	00600 5	4	20.3	3.60
5	S700D	Best	Round point shovel	#2 rear roll step	9" x 12"	Square	PermaGrip®	29" fiberglass	Poly D	01700 1	4	16.0	2.60
6	S701D	Best	Square point shovel	#2 rear roll step	9.5" x 11.5"	Square	PermaGrip®	29" fiberglass	Poly D	01701 8	4	18.0	2.60
7	S601	Best	Square point shovel	#2 front turn step	9.5" x 11"	Square	PermaGrip®	48" fiberglass	Cushion	00601 2	4	21.8	3.67
8	S600D	Best	Round point shovel	#2 front turn step	9" x 11.5"	Square	PermaGrip®	29" fiberglass	Poly D	01600 4	4	17.5	2.60
9	S601D	Best	Square point shovel	#2 front turn step	9.5" x 11"	Square	PermaGrip®	29" fiberglass	Poly D	01601 1	4	19.0	2.67
10	BR16	Best	Bow rake	Forged 16 Tine	16.25" x 3.25"	—	Nylon	60" fiberglass	Cushion	00516 9	4	13.0	3.49
11	H800	Best	Garden hoe	Forged	6" x 4"	—	Nylon	60" fiberglass	Cushion	00800 9	4	9.6	1.30

STRUCTRON® brand garden spades & drain spades



Garden spades are used to turn soil in flower and vegetable gardens. Can also be used for edging along flower beds, walks, and drives.

Drain spades are used to dig and clean out narrow spaces. Also used to transplant nursery stock and bushes.

14 gauge shovel heads



Photo No.	Model	Quality Level	Description	Head Style	Head size W x H	Socket	Ferrule	Handle	Grip	UPC 0 36723 +	Pack Qty.	Pack Wgt.	Pack Cube
1	S705	Best	Garden spade	#2 rear roll step	7.5" x 12"	Square	PermaGrip®	48" fiberglass	Cushion	00705 7	4	18.3	1.25
2	S705D	Best	Garden spade	#2 rear roll step	7.5" x 12"	Square	PermaGrip®	29" fiberglass	Poly D	01705 6	4	16.5	0.86
3	S605	Best	Garden spade	#2 front turn step	6.9" x 12"	Square	Steel	48" fiberglass	Cushion	00605 0	4	18.5	1.25
4	S605D	Best	Garden spade	#2 front turn step	6.9" x 12"	Square	Steel	29" fiberglass	Poly D	01605 9	4	18.3	0.86
5	S704	Best	Drain spade	Rear roll step	5.5" x 14"	Square	PermaGrip®	48" fiberglass	Cushion	00704 0	4	19.0	1.25
6	S704D	Best	Drain spade	Rear roll step	5.5" x 14"	Square	PermaGrip®	29" fiberglass	Poly D	01704 9	4	17.0	0.75
7	S604	Best	Drain spade	Front turn step	5.5" x 16"	Square	PermaGrip®	48" fiberglass	Cushion	00604 3	4	20.0	1.26
8	S604D	Best	Drain spade	Front turn step	5.5" x 16"	Square	PermaGrip®	29" fiberglass	Poly D	01604 2	4	17.3	1.25



STRUCTRON® forged-head solid-shank shovels and spades

Forged-head solid-shank tools are ideal for the heaviest-duty industrial applications.

To make these rugged tools, the head, shank, and socket are all forged from a single piece of bar steel. A solid steel section (shank) in the neck joins the blade and the socket and provides maximum strength at this critical stress point.

Forged heads are heavier and thicker than stamped heads, so they don't need a frog in the blade and thus won't collect and hold material. The thicker forged blades wear longer than stamped blades.

Rugged forged-head solid-shank design.

The head, shank, and socket are all forged from a single piece of bar steel for exceptional strength and long life. They are ideal for heavy-duty contractor and industrial applications. They feature the world's strongest fiberglass and American ash handles.



Model	Description	Head size W x H	Handle	Grip	UPC	Pack qty.	Pack wgt.	Pack cube
1 S800	Round point shovel	9" x 11.5"	45.5" fiberglass	Cushion	0 36723 00800 9	4	21.4	3.74
2 S801	Square point shovel	9.25" x 12"	45.5" fiberglass	Cushion	0 36723 00801 6	4	22.2	4.18
3 S805D	Garden spade	7" x 12"	29" fiberglass	Poly D	0 36723 01805 3	4	22.8	1.94
4 S715D	Drain spade	5.5" x 16"	29" fiberglass	Poly D	0 36723 01715 5	4	19.2	0.91
5 S715	Drain spade	5.5" x 16"	45.5" fiberglass	Cushion	0 36723 00715 6	4	23.1	1.31
6 S819D	Post spade	5" x 16"	29" fiberglass	Poly D	0 36723 01819 0	4	20.8	1.12
7 S707	Caprock irrigation shovel	9.5" x 9.9"	45.5" fiberglass	Cushion	0 36723 00707 1	4	21.0	1.75
7 S707S	Caprock irrigation shovel	9.5" x 9.9"	44.5" solid fbrgls	Cushion	0 36723 01707 0	4	28.4	1.75
8 S714	Irrigation shovel	7" x 9.5"	45.5" fiberglass	Cushion	0 36723 00714 9	4	21.0	3.10

SEYMOUR® forged-head solid-shank shovels and spades



The best tools cost less in the long run.

Cheap tools are never a bargain. They will break and need to be replaced when you need them most. When you buy Seymour and Structron premium forged-head solid shank tools, you are getting the world's best tools. They won't let you down.

Best handles in the business for forged tools.

Strong tools need strong handles as well as well as strong heads. Seymour handles are the best you can buy on forged-head tools.



Model	Description	Head size W x H	Handle	Grip	UPC	Pack qty.	Pack wgt.	Pack cube
9 SV-LR50	Round point shovel	9" x 11.5"	46.5" hardwood	---	0 31365 80000 4	4	18.6	3.74
10 SV-LS51	Square point shovel	9.25" x 12"	46.5" hardwood	---	0 31365 80001 1	4	19.4	4.18
11 SV-DR52	Round point shovel	9" x 11.5"	27" hardwood	Steel D	0 31365 80007 3	4	16.6	2.42
12 SV-DS53	Square point shovel	9.25" x 12"	27" hardwood	Steel D	0 31365 80008 0	4	17.4	2.66
13 SV-GD50	Garden spade	7" x 12"	27" hardwood	Steel D	0 31365 80004 2	4	17.2	1.94
14 SV-DD50	Drain spade	5.5" x 16"	27" hardwood	Steel D	0 31365 80005 9	4	16.4	0.91
15 SV-PD50	Post spade	5" x 16"	27" hardwood	Steel D	0 31365 80006 6	4	18.0	1.12
16 SV-CR50	Caprock irrigation shovel	9.5" x 9.9"	46.5" hardwood	---	0 31365 80002 8	4	18.2	1.31
17 SV-IR50	Irrigation shovel	7" x 9.5"	46.5" hardwood	---	0 31365 80003 5	4	18.2	3.10

PROFESSIONAL fiberglass handle tools

Contractor grade tools designed for frequent heavy-duty use by farmers, ranchers, contractors, and other professionals with demanding industrial and commercial applications.

16 gauge shovel heads

Heavy-duty fiberglass core insert provides extra strength at this point of greatest stress.

PermaGrip® steel collar is a rivetless ring of steel that connects the shovel neck, handle, and core insert making one solid unit.

- Durable heat-treated carbon steel heads with black painted finish.
- Front turn steps on shovel heads provides secure foot placement and comfort.
- Square-shoulder 9-inch sockets on shovel heads.

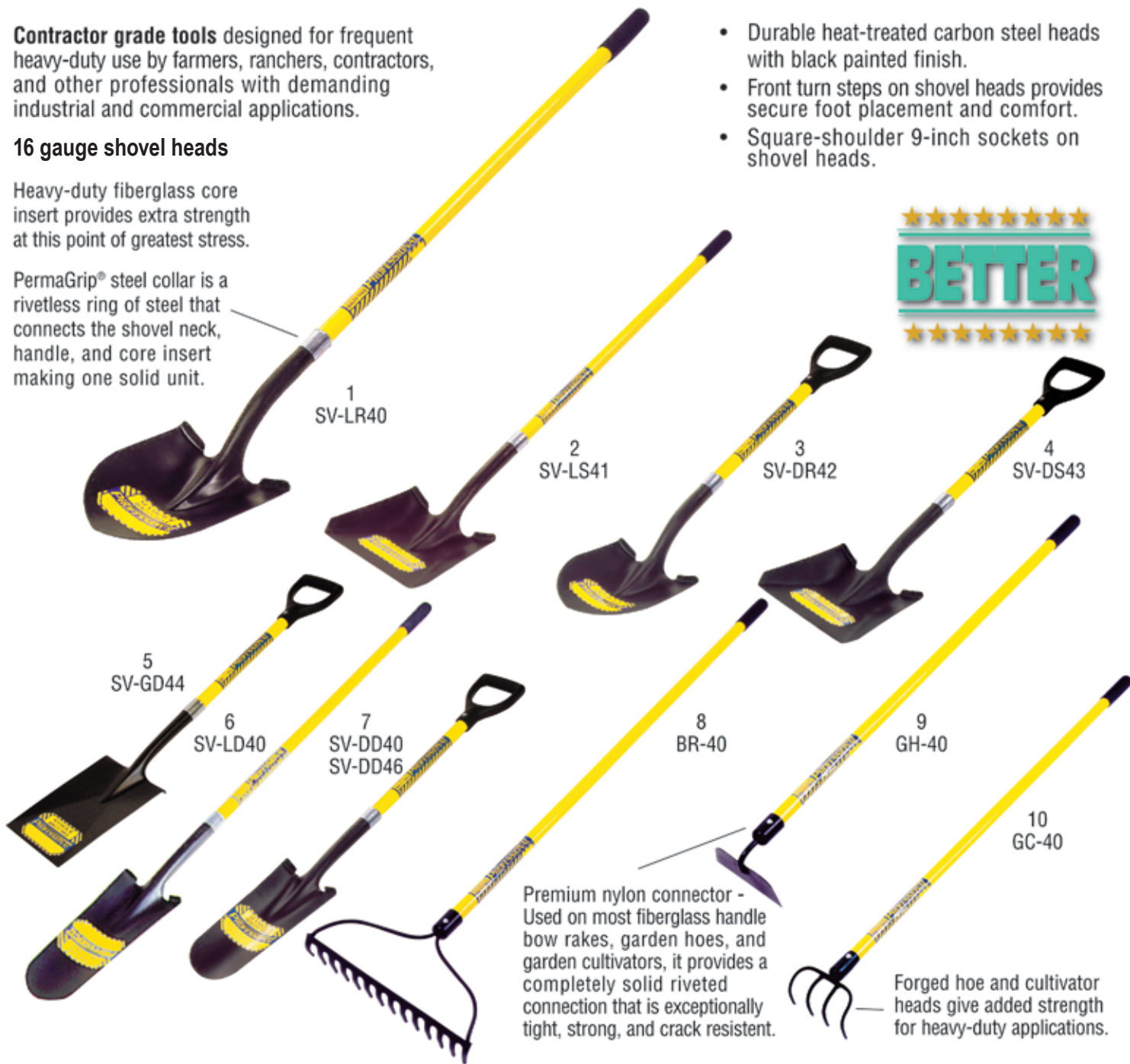

Premium nylon connector - Used on most fiberglass handle bow rakes, garden hoes, and garden cultivators, it provides a completely solid riveted connection that is exceptionally tight, strong, and crack resistant.

Forged hoe and cultivator heads give added strength for heavy-duty applications.

Photo No.	Model	Quality Level	Description	Head Style	Head size W x H	Socket	Collar	Handle	Grip	UPC 0 31365 +	Pack Qty.	Pack Wgt.	Pack Cube
1	SV-LR40	Better	Round point shovel	#2 front turn step	8.8" x 11.5"	Square	PermaGrip®	46" fiberglass	Vinyl	12007 2	6	23.2	2.34
2	SV-LS41	Better	Square point shovel	#2 front turn step	9.7" x 11.5"	Square	PermaGrip®	46" fiberglass	Vinyl	12008 9	6	24.0	2.65
3	SV-DR42	Better	Round point shovel	#2 front turn step	8.8" x 11.5"	Square	PermaGrip®	28" fiberglass	Poly D	12104 8	6	21.3	3.34
4	SV-DS43	Better	Square point shovel	#2 front turn step	9.7" x 11.5"	Square	PermaGrip®	28" fiberglass	Poly D	12105 5	6	22.1	2.00
5	SV-GD44	Better	Garden spade	#2 rear turn step	7" x 12"	Square	PermaGrip®	28" fiberglass	Poly D	12205 2	6	20.8	2.00
6	SV-LD40	Better	Drain spade	Front turn step	5.5" x 14"	Square	PermaGrip®	46" fiberglass	Vinyl	12308 0	6	24.9	3.42
7	SV-DD40	Better	Drain spade	Front turn step	5.5" x 14"	Square	PermaGrip®	28" fiberglass	Poly D	12340 0	6	19.5	1.04
7	SV-DD46	Better	Drain spade, 14 gauge	Front turn step	5.5" x 16"	Square	PermaGrip®	28" fiberglass	Poly D	12303 5	6	25.2	1.09
8	BR-40	Better	Bow rake	Welded 14-tine	15" x 3.5"	—	Nylon	60" fiberglass	Vinyl	12500 8	6	21.2	4.74
9	GH-40	Better	Garden hoe	Forged	6" x 4.25"	—	Nylon	54" fiberglass	Vinyl	12600 5	6	14.8	2.90
10	GC-40	Better	Garden cultivator	Forged 4-tine	5" x 5.5"	—	Nylon	54" fiberglass	Vinyl	12700 2	6	12.5	1.09

Homeowner grade tools with features usually found only on more expensive tools. They provide exceptional value in an economical line of fiberglass handle tools designed for homeowner and other occasional use applications.

16 gauge shovel heads

Durable heat-treated carbon steel heads with clear lacquer finish.

PermaGrip® steel collar adds strength and stays tight.



- Square-shoulder 9-inch sockets on shovel heads.
- Front turn steps on shovel heads.
- Welded rake and hoe heads provide value and economy for homeowner applications.
- Red fiberglass handles with black vinyl grips.



DuraLite® fiberglass handles use solid hardwood core inserts to provide extra strength at the point of greatest stress.



SEYMOUR
THE WORLD'S BEST TOOLS!
STRUCTRON

Photo No.	Model	Quality Level	Description	Head Style	Head size W x H	Socket	Ferrule	Handle	Grip	UPC 0 31365 +	Pack Qty.	Pack Wgt.	Pack Cube
1	SV-LR80	Good	Round point shovel	#2 front turn step	8.8" x 11.5"	Square	PermaGrip®	43" fiberglass	Vinyl	12024 9	6	20.6	2.85
2	SV-LS81	Good	Square point shovel	#2 front turn step	9.7" x 11.5"	Square	PermaGrip®	43" fiberglass	Vinyl	12023 2	6	22.3	2.95
3	SV-DR82	Good	Round point shovel	#2 front turn step	8.8" x 11.5"	Square	PermaGrip®	26" fiberglass	Poly D	12026 3	6	20.3	2.04
4	SV-DS83	Good	Square point shovel	#2 front turn step	9.7" x 11.5"	Square	PermaGrip®	26" fiberglass	Poly D	12025 6	6	22.0	2.04
5	SV-DD80	Good	Drain spade	Front turn step	5" x 14"	Square	PermaGrip®	26" fiberglass	Poly D	12304 2	6	19.9	1.04
6	BR-80	Good	Bow rake	Welded 14-tine	13.75" x 3"	—	Nylon	48" fiberglass	Vinyl	12506 0	6	13.3	3.31
7	GH-80	Good	Garden hoe	Welded	6" x 4.25"	—	Nylon	48" fiberglass	Vinyl	12604 3	6	11.3	1.63

INDUSTRIAL wood handle tools

The most rugged wood handle tools available for the heaviest duty construction, industrial, and commercial applications.

Super tough coating on hardwood handles repels water better and is more durable in sunlight than conventional lacquers.

14 gauge shovel heads

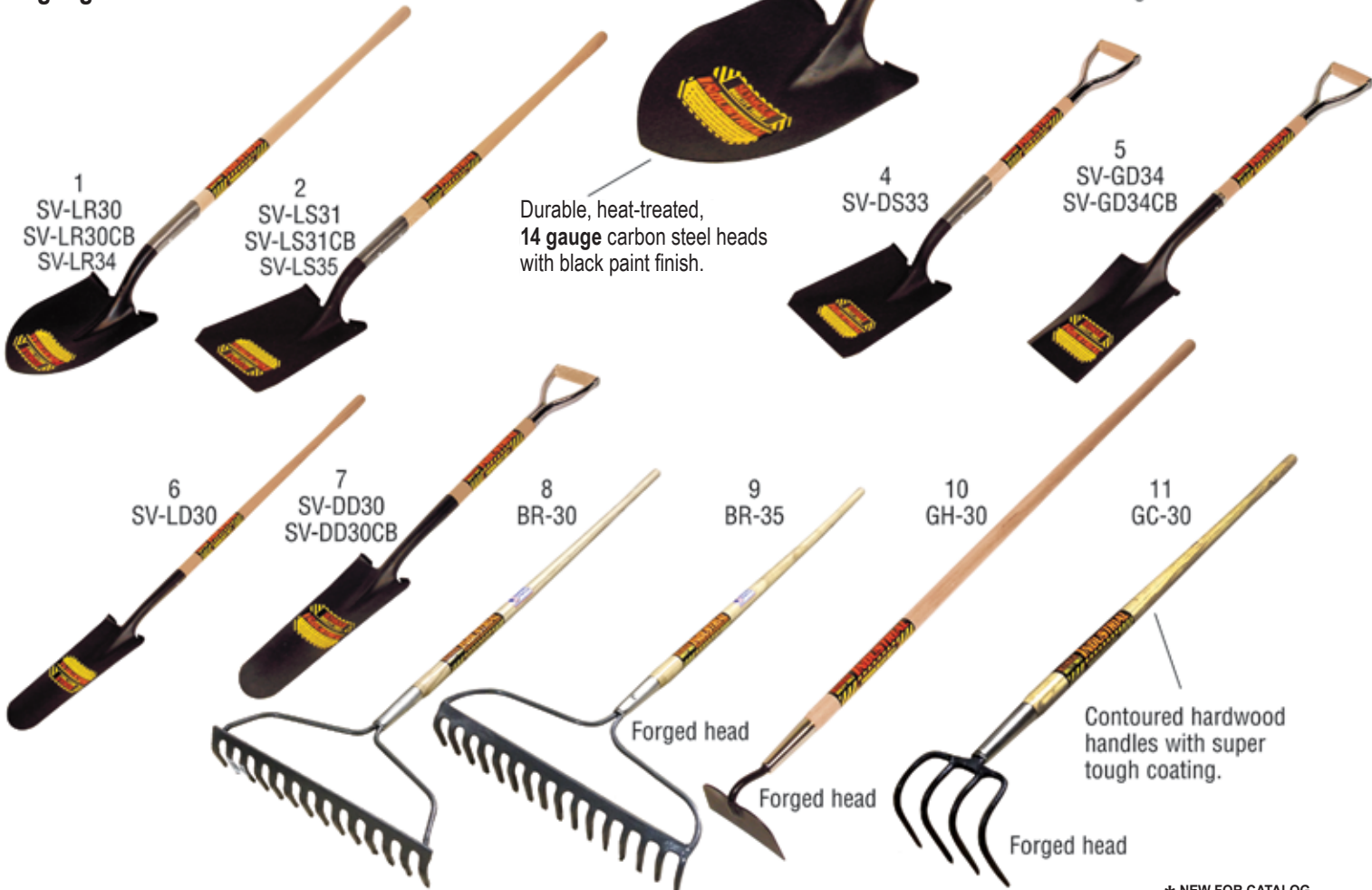

* NEW FOR CATALOG

Photo No.	Model	Quality Level	Description	Head Style	Head size W x H	Socket	Ferrule	Handle	Grip	UPC 0-31365 +	Pack Qty.	Pack Wgt.	Pack Cube
1	SV-LR30	Best	Round point shovel	#2 front turn step	8.8" x 12"	Ext. tab 11"	—	48" hardwood	—	12003 4	6	25.9	3.60
1	SV-LR30CB	Best	Round point shovel	#2 closed back	8.8" x 12"	Ext. tab 11"	—	48" hardwood	—	12032 4	6	28.8	3.60
1	* SV-LR34	Best	Round point shovel	#2 rear rolled step	8.8" x 12"	Ext. tab 11"	—	48" hardwood	—	12148 2	6	32.0	3.60
2	SV-LS31CB	Best	Square point shovel	#2 closed back	9.5" x 11.7"	Ext. tab 11"	—	48" hardwood	—	12000 3	6	30.4	2.65
2	SV-LS31	Best	Square point shovel	#2 front turn step	9.5" x 11.7"	Ext. tab 11"	—	48" hardwood	—	12004 1	6	27.5	2.65
2	* SV-LS35	Best	Square point shovel	#2 rear rolled step	9.5" x 11.7"	Ext. tab 11"	—	48" hardwood	—	12147 5	6	31.5	2.65
3	SV-DR32	Best	Round point shovel	#2 front turn step	8.8" x 12"	Ext. tab 11"	—	30" hardwood	Steel D	12100 0	6	25.0	3.34
4	SV-DS33	Best	Square point shovel	#2 front turn step	9.5" x 11.7"	Ext. tab 11"	—	30" hardwood	Steel D	12102 4	6	27.4	3.34
5	SV-GD34	Best	Garden spade, 16 gauge	#2 rear turn step	7" x 12"	Square 9"	Steel Collar	30" hardwood	Steel D	12200 7	6	28.7	2.00
5	SV-GD34CB	Best	Garden spade, 16 gauge	#2 closed back	7" x 12"	Square 9"	Steel Collar	30" hardwood	Steel D	11999 1	6	29.5	2.00
6	SV-LD30	Best	Drain spade	Front turn step	5.5" x 16"	Square 9"	—	48" hardwood	—	12306 6	6	24.6	1.90
7	SV-DD30	Best	Drain spade	Front turn step	5.5" x 16"	Square 9"	—	30" hardwood	Steel D	12300 4	6	23.4	1.66
7	SV-DD30CB	Best	Drain spade	Closed back	5.5" x 16"	Square 9"	—	30" hardwood	Steel D	12132 1	6	24.7	1.66
8	BR-30	Best	Bow rake	Welded 14-tine	15" x 3.5"	—	Steel	60" hardwood	—	12501 5	6	21.9	4.74
9	BR-35	Best	Bow rake	Forged 16-tine	16.25" x 3.25"	—	Steel	60" hardwood	—	12503 9	6	23.5	3.47
10	GH-30	Best	Garden hoe	Forged	6" x 4.25"	—	Steel	60" hardwood	—	12601 2	6	15.2	2.90
11	GC-30	Best	Garden cultivator	Forged 4-tine	5" x 5.5"	—	Steel	54" hardwood	—	12701 9	6	14.3	1.09

Contractor grade tools are designed for frequent heavy-duty use by farmers, ranchers, contractors and other professionals with demanding industrial and commercial applications.

Round point shovels are used mainly for digging. Can also be used to move sand, gravel, and other loose materials.

Square point shovels are used mainly for moving sand, gravel, and other loose materials. Can also be used for snow removal, scraping, and clean-up.

16 gauge shovel heads

Steel collars for strong handle to head connection.



- Front turn steps on shovel heads provides secure foot placement and comfort.
- Welded rake, hoe, and cultivator heads.
- Contoured hardwood handles with super tough coating.

SEYMOUR
THE WORLD'S BEST TOOLS
STRUCTRON

Durable heat-treated carbon steel heads with blue painted finish.



Square-shoulder 9-inch sockets on shovel heads.

Photo No.	Model	Quality Level	Description	Head Style	Head size W x H	Socket	Collar	Handle	Grip	UPC 0 31365 +	Pack Qty.	Pack Wgt.	Pack Cube
1	SV-LR20	Better	Round point shovel	#2 front turn step	8.8" x 11.5"	Square	Steel	48" hardwood	—	12005 8	6	24.6	2.34
2	SV-LS21	Better	Square point shovel	#2 front turn step	9.7" x 11.5"	Square	Steel	48" hardwood	—	12006 5	6	25.4	2.65
3	SV-DR22	Better	Round point shovel	#2 front turn step	8.8" x 11.5"	Square	Steel	30" hardwood	Poly D	12101 7	6	22.3	3.34
4	SV-DS23	Better	Square point shovel	#2 front turn step	9.7" x 11.5"	Square	Steel	30" hardwood	Poly D	12103 1	6	23.5	2.00
5	SV-GD24	Better	Garden spade	#2 rear turn step	7" x 12"	Square	—	30" hardwood	Poly D	12201 4	6	24.8	2.00
6	SV-GL24	Better	Garden spade	#2 rear turn step	7" x 12"	Square	—	48" hardwood	—	12202 1	6	23.7	2.12
7	SV-DD20	Better	Drain spade	Front turn step	5.5" x 14"	Square	—	30" hardwood	Poly D	12301 1	6	20.7	1.14
8	SV-LD20	Better	Drain spade	Front turn step	5.5" x 14"	Square	—	48" hardwood	—	12305 9	6	23.4	1.85
9	BR-20	Better	Bow rake	Welded 14-tine	15" x 3.5"	—	Steel ferrule	54" hardwood	—	12502 2	6	19.0	4.33
10	GH-20	Better	Garden hoe	Welded	6" x 4.25"	—	Steel ferrule	54" hardwood	—	12602 9	6	12.3	2.63
11	GC-20	Better	Garden cultivator	Welded 4-tine	4.7" x 3.7"	—	Steel ferrule	54" hardwood	—	12702 6	6	11.4	1.09



VALUE*PLUS™ wood handle tools

Outstanding value is the key benefit of VALUE*PLUS™ tools, a good quality tool line designed for the most rigorous homeowner use and other demanding applications.



16 gauge shovel heads



- Durable heat-treated carbon steel heads with clear lacquer finish.
- Front turn steps on shovel heads.
- Square-shoulder 9-inch sockets on shovel heads.
- Welded rake, hoe, and cultivator heads provide value and economy for homeowner applications.
- Contoured hardwood handles with double-coated clear lacquer finish.
- Red metal D-grips for comfort and secure grip.

Photo No.	Model	Quality Level	Description	Head Style	Head size W x H	Socket	Ferrule	Handle	Grip	UPC 0 31365 +	Pack Qty.	Pack Wgt.	Pack Cube
1	SV-LR10	Good	Round point shovel	#2 front turn step	8.8" x 11.5"	Square	—	44" hardwood	—	12013 3	6	24.0	3.63
2	SV-LS11	Good	Square point shovel	#2 front turn step	9.7" x 11.5"	Square	—	44" hardwood	—	12014 0	6	26.6	3.83
3	SV-DR12	Good	Round point shovel	#2 front turn step	8.8" x 11.5"	Square	—	26" hardwood	Steel D	12120 8	6	23.3	2.46
4	SV-DS13	Good	Square point shovel	#2 front turn step	9.7" x 11.5"	Square	—	26" hardwood	Steel D	12122 2	6	25.8	2.78
5	SV-GD10	Good	Garden spade	#2 rear turn step	6.6" x 11.5"	Square	—	26" hardwood	Steel D	12204 5	6	22.1	1.67
6	SV-DD10	Good	Drain spade	Rear roll step	4.75" x 14"	Square	—	26" hardwood	Steel D	12317 2	6	22.2	1.71
7	BR-10	Good	Bow rake	Welded 14-tine	13.7" x 3"	—	Steel	54" hardwood	—	12507 7	6	19.6	3.37
8	GH-10	Good	Garden hoe	Welded	6" x 4.25"	—	Steel	54" hardwood	—	12605 0	6	14.9	2.39
9	GC-10	Good	Garden cultivator	Welded 4-tine	4.7" x 3.7"	—	Steel	54" hardwood	—	12526 8	6	13.6	1.78

Economy grade tools providing basic hand tools at minimum cost. The Seymour 90 Series is a promotional line of tools designed for occasional use applications where low cost is the primary consideration.



- **16 gauge shovel heads**
- Rear rolled steps on shovel heads
- Square-shoulder, 9-inch sockets on shovel heads.



Black metal D-grips for comfort and a secure grip.

Contoured hardwood shovel handles and straight rake and hoe handles with clear lacquer finish.

Welded rake and hoe tool heads provide value and economy for homeowner applications.

Durable heat-treated carbon steel heads with clear lacquer finish.

Bow rakes have slightly rounded teeth for gathering stones and large weeds and for seedbed preparation. The bow provides some spring to reduce fatigue.

Photo No.	Model	Quality Level	Description	Head Style	Head size W x H	Socket	Ferrule	Handle	Grip	UPC 0 31365 +	Pack Qty.	Pack Wgt.	Pack Cube
1	SV-LR90	Promo	Round point shovel	#2 rear roll step	8.2" x 11.5"	Square	—	42" hardwood	—	12017 1	6	22.0	3.31
2	SV-LS91	Promo	Square point shovel	#2 rear roll step	9.2" x 11.5"	Square	—	42" hardwood	—	12018 8	6	24.8	3.67
3	SV-DR92	Promo	Round point shovel	#2 rear roll step	8.2" x 11.5"	Square	—	26" hardwood	Steel D	12027 0	6	22.9	2.32
4	SV-DS93	Promo	Square point shovel	#2 rear roll step	9.2" x 11.5"	Square	—	26" hardwood	Steel D	12028 7	6	24.9	2.56
5	BR-90	Promo	Bow rake	Welded 14-tine	13.75" x 3"	—	Steel	48" hardwood	—	12508 4	6	17.2	3.28
6	GH-90	Promo	Garden hoe	Welded	6" x 4.25"	—	Steel	48" hardwood	—	12606 7	6	11.7	1.95

SEYMOUR® & STRUCTION® brand specialty shovels

Super Shovel® tools have cutting teeth to penetrate hard-packed, rocky and clay soils. Also chop through roots and sod.

Irrigation shovels are used to easily dig vertical channels because of low lift angle.

Caprock irrigation shovels feature forged heads and low lift for near vertical digging. The solid shank provides exceptional strength.

Rice shovels are used for rice farming and irrigation. The perforations allow draining and ease of suction break.

MiniPRO™ shovels are rugged little shovels with a wide variety of home and commercial applications. Ideal for car trunks, camping, gardening, tight places, concrete work, and track cleaning on heavy equipment.



* NEW FOR CATALOG

Photo No.	Model	Quality Level	Description	Head Style	Head size W x H	Socket	Ferrule	Handle	Grip	UPC	Pack Qty.	Pack Wgt.	Pack Cube
1	S710	Best	Super Shovel	#2 front turn step	8.8" x 11.2"	Square	Steel	48" fiberglass	Cushion	0 36723 00710	1	4	20.0 3.50
2	S710D	Best	Super Shovel	#2 front turn step	8.8" x 11.2"	Square	Steel	29" fiberglass	Poly D	0 36723 01710	0	4	17.2 3.25
3	SV-LT34	Best	Super Shovel	#2 front turn step	8.8" x 11.2"	Square	Steel	48" hardwood	—	0 31365 12031	7	6	28.1 5.82
4	SV-DT35	Best	Super Shovel	#2 front turn step	8.8" x 11.2"	Square	Steel	29" hardwood	Steel D	0 31365 12030	0	6	26.1 3.25
5	S706	Best	Irrigation shovel	Front turn step	9.5" x 12"	Square	PermaGrip®	48" fiberglass	Cushion	0 36723 00706	4	4	17.5 3.60
6	S714	Best	Irrigation shovel	Forged #00	7" x 9.5"	Square	PermaGrip®	48" fiberglass	Cushion	0 36723 00714	9	4	20.0 3.00
7	S707	Best	Caprock irrigation	Forged #2	9.5" x 9.9"	Square	Steel	48" fiberglass	Cushion	0 36723 00707	1	4	20.0 3.25
7	S707S	Best	Caprock irrigation	Forged #2	9.5" x 9.9"	Square	Steel	48" solid fg	Cushion	0 36723 01707	0	4	27.6 3.25
8	SV-LR25	Better	Floral and fire shovel	#0 front turn step	7.25" x 10"	Square	—	44" hardwood	—	0 31365 12199	4	6	21.3 2.29
9	SV-RS20	Better	Rice shovel	Perforated rnd pt	8.5" x 10.25"	Square	—	48" hardwood	—	0 31365 12002	7	6	23.5 2.96
10	SV-RS40	Better	Rice shovel	Perforated rnd pt	8.5" x 10.25"	Square	Steel	46" fiberglass	Vinyl	0 31365 12001	0	6	21.4 3.19
11	S713	Best	Rice shovel	Perforated rnd pt	9" x 10.5"	Square	PermaGrip®	48" fiberglass	Cushion	0 36723 00713	2	4	17.5 3.60
12	SV-DRMP	Better	MiniPRO round point	Floral, front turn	6" x 8"	Square	—	17" hardwood	Poly D	0 31365 12108	6	6	11.8 0.99
13	SV-DRMPFG	Better	MiniPRO round point	Floral, front turn	6" x 8"	Square	PermaGrip®	17" fiberglass	Poly D	0 31365 12111	6	6	13.3 0.99
14	SV-DSMP	Better	MiniPRO square point	Floral, front turn	6" x 8.25"	Square	—	17" hardwood	Poly D	0 31365 12124	6	6	12.0 0.99
15 *	SV-DRCH	Better	Ceremonial shovel, Chrome head, rear turn step	8.8" x 11.2"	Square	Steel	—	23" hardwood	NiCr D	0 31365 12119	2	1	5.2 1.10

Trenching and clean-out shovels



Trench clean-out shovels with no step are economical tools for cleaning loose materials from trenches prior to laying wire, cable or pipe.

Trenching shovels with rear rolled steps can be used for light digging, as well as clean-out.

Trenching/clean-out shovels with front turn steps can be used for both trench digging and clean-out. The V-shape blade provides maximum blade strength and helps shape the trench bottom for best positioning of wire, cable, or pipe.



Photo No.	Model	Quality Level	Description	Head Style	Head size W x H	Collar	Handle	Grip	UPC	Pack Qty.	Pack Wgt.	Pack Cube
1	SV-TR14	Good	Trench cleanout shovel	Rear roll step	4" x 12"	—	44" hardwood	—	0 31365 10709 7	6	17.1	1.17
1	SV-TR15	Good	Trench cleanout shovel	Rear roll step	5" x 12"	—	44" hardwood	—	0 31365 10711 0	6	17.4	1.46
2	SV-TR44	Better	Trench cleanout shovel	Rear roll step	4" x 12"	PermaGrip®	45" fiberglass	Vinyl	0 31365 10715 8	6	17.3	1.45
2	SV-TR45	Better	Trench cleanout shovel	Rear roll step	5" x 12"	PermaGrip®	45" fiberglass	Vinyl	0 31365 10716 5	6	18.5	1.76
3	SV-TR22	Better	Trenching/cleanout shovel	Front turn step	1.5" x 11.5"	—	48" hardwood	—	0 31365 10722 6	6	18.6	1.97
3	SV-TR23	Better	Trenching/cleanout shovel	Front turn step	3" x 11.5"	—	48" hardwood	—	0 31365 10712 7	6	18.6	1.97
3	SV-TR24	Better	Trenching/cleanout shovel	Front turn step	4" x 11.5"	—	48" hardwood	—	0 31365 10713 4	6	20.4	2.30
3	SV-TR25	Better	Trenching/cleanout shovel	Front turn step	5" x 11.5"	—	48" hardwood	—	0 31365 10717 2	6	21.6	2.63
4	SV-TR401	Better	Trenching/cleanout shovel	Front turn step	1.5" x 11.5"	—	51" fiberglass	Vinyl	0 31365 10718 9	6	19.2	2.04
4	SV-TR403	Better	Trenching/cleanout shovel	Front turn step	3" x 11.5"	—	51" fiberglass	Vinyl	0 31365 10719 6	6	19.2	2.04
4	SV-TR404	Better	Trenching/cleanout shovel	Front turn step	4" x 11.5"	—	51" fiberglass	Vinyl	0 31365 10720 2	6	21.0	2.37
4	SV-TR405	Better	Trenching/cleanout shovel	Front turn step	5" x 11.5"	—	51" fiberglass	Vinyl	0 31365 10721 9	6	22.2	2.70
5	S702	Best	Trenching shovel	Front turn step	5" x 11.5"	PermaGrip®	48" fiberglass	Cushion	0 36723 00702 6	4	17.5	1.50
5	S703	Best	Trenching shovel	Front turn step	4" x 11.5"	PermaGrip®	48" fiberglass	Cushion	0 36723 00703 3	4	16.5	1.25
6	S716	Best	Trenching/cleanout shovel	Front turn step	1.5" x 11.5"	PermaGrip®	54" fiberglass	Cushion	0 36723 00716 3	4	13.0	1.25
6	S708	Best	Trenching/cleanout shovel	Front turn step	3" x 11.5"	PermaGrip®	54" fiberglass	Cushion	0 36723 00708 8	4	15.0	1.50
6	S709	Best	Trenching/cleanout shovel	Front turn step	4" x 11.5"	PermaGrip®	54" fiberglass	Cushion	0 36723 00709 5	4	16.0	1.25
6	S717	Best	Trenching/cleanout shovel	Front turn step	5" x 11.5"	PermaGrip®	54" fiberglass	Cushion	0 36723 00717 0	4	17.0	1.75

Lady Floral Tools

PREMIUM TOOLS FOR HANDS THAT MAKE THE WORLD MORE BEAUTIFUL

Lady Floral tools are the perfect fit for gardens, tight spaces and smaller hands. They are smaller, lighter, and easy to use, yet made from the same rugged materials as full-size tools.

Floral-size heads are made from tempered high carbon steel for superior strength. Models with forged heads provide the ultimate in durability.

Premium hardwood handles feature slim design for lighter weight and ease of handling. D-handle tools feature full-size poly D-grips for easy grip and comfort with or without gloves.



* NEW FOR CATALOG

Photo No.	Model	Quality Level	Description	Head Style	Head size W x H	Socket	Ferrule	Handle	Grip	UPC 0 31365 +	Pack Qty.	Pack Wgt.	Pack Cube
1	SV-LR70	Best	Round point shovel	Floral, front turn step	6" x 8"	Square	—	44" hardwood	—	12706 4	6	15.9	1.63
2	SV-DR72	Best	Round point shovel	Floral, front turn step	6" x 8"	Square	—	30" hardwood	Poly D	13107 8	6	14.7	1.54
3	SV-DS73	Best	Square point shovel	Floral, front turn step	6" x 8.25"	Square	—	30" hardwood	Poly D	12051 5	6	14.7	1.54
4	VH-70	Best	V-hoe	Forged	4" x 5"	—	Steel	54" hardwood	—	12612 8	6	9.9	1.46
5	GC-70	Best	Garden cultivator	Forged, 3-line	3.5" x 5"	—	Steel	54" hardwood	—	12705 7	6	9.4	1.45
6	SK-70H	Best	Soil knife	Forged	2" x 4.25"	—	Steel	15" hardwood	—	10040 1	6	4.2	0.37
7	WH-70H	Best	Weeding hoe	Forged	2.5" x 4"	—	Steel	15" hardwood	—	05125 3	6	4.7	0.37
8	GC-70H	Best	Garden cultivator	Forged, 3-line	3.5" x 5"	—	Steel	15" hardwood	—	12707 1	6	4.3	0.37
9	WE-70H	Best	Dandelion weeder	Forged	1" x 3"	—	Steel	15" hardwood	—	05036 2	6	3.4	0.37
10	NT-70H	Best	Nursery trowel	Forged	3.75" x 6"	—	Steel	15" hardwood	—	05318 9	6	5.8	0.37
11	* FR-70	Best	Level head rake	Forged	3" x 8"	—	Steel	15" hardwood	—	12713 2	6	10.2	2.10
12	* LF-70	Best	Leaf rake, poly head	Poly	8" x 8"	—	—	15" hardwood	—	12714 9	6	10.1	1.95

Seymour Garden Tools

PREMIUM TOOLS FOR HANDS THAT MAKE THE WORLD MORE BEAUTIFUL

Seymour developed these short-handled tools to better meet the needs of home gardeners who prefer more compact tools.

We added these four new tools have chrome plated heads with hardwood handles and a convenient hole to hang up when not in use.

They're durable and feel great in your hands.



Photo No.	Model	Quality Level	Description	Head Style	Head size W x H	UPC 0 31365 +	Pack Qty.	Pack Wgt.	Pack Cube
1 *	WP-5401	Better	Hand transplanter, wood handle	Chrome	2.5" x 6"	15401 5	12	5.88	.20
2 *	WP-5403	Better	Hand cultivator, wood handle	Chrome	3" x 5"	15403 9	12	5.88	.21
3 *	WP-5402	Better	Hand dandelion weeder, wood handle	Chrome	.75" x 2.5"	15402 2	12	3.48	.18
4 *	WP-5400	Better	Hand trowel, wood handle	Chrome	3.5" x 6"	15400 8	12	6.48	.21

* NEW FOR CATALOG

Posthole diggers



SEYMOUR® posthole diggers have been and always will be 100% American made. That's why all of our posthole diggers are branded with the All-American™ brand by SEYMOUR®.

SEYMOUR® manufactures the most complete line of posthole diggers in the industry, consisting of 25 different diggers; made by the American worker for the world.

Photo No.	Model	Quality Level	Description	Head Color	Point Spread	Handle	Grip	UPC 0 31365 +	Pack Qty.	Pack Wgt.	Pack Cube
1	DG-25	Good	Junior Atlas digger	Black	5	42" hardwood	—	01240 7	2	11.5	0.83
2	DG-60	Promo	Promotional digger	Clear	5	4' hardwood	—	01112 7	2	14.5	1.03
3	DG-75	Better	Homeowner digger	Orange	5	4' hardwood	—	01244 5	2	14.5	1.03
4	DG-80FG	Promo	DuraLite digger	Clear	5	4' fiberglass	Vinyl	01116 5	2	14.0	1.03
5	DG-100	Better	Special Atlas digger	Red	5	4' hardwood	—	01110 3	2	16.0	1.03
6	DG-100FG	Better	Special Atlas digger	Clear	6	4' fiberglass	Vinyl	01600 9	2	15.0	1.03
7	DG-10	Best	Heavy-duty Atlas digger	Blue	5	4' hardwood	—	01010 6	2	16.0	1.03
	DG-106	Best	Heavy-duty Atlas digger	Blue	5	6' hardwood	—	01030 4	2	20.4	1.44
	DG-108	Best	Heavy-duty Atlas digger	Blue	5	8' hardwood	—	01050 2	2	25.0	1.86
8	DG-17	Best	Extra heavy-duty Atlas digger	Blue	5	4' hardwood	—	01205 6	2	17.0	1.03
9	DG-17FG	Best	Extra heavy-duty Atlas digger	Clear	6	4' fiberglass	Vinyl	01602 3	2	19.4	1.03

Posthole diggers



Atlas pattern diggers are best suited for homeowner use and other occasional use applications.

Hercules pattern digger heads provide maximum strength for the most demanding industrial and commercial jobs.

Hercules Lonestar diggers feature strong tubular steel handles welded to thick yokes for digging in the hardest soils.

Buckeye diggers feature strong steel pipe handles welded to square steel shanks and yoke. Super-tough square-cut steel blades are ideal for digging in heavy, rocky soils.

Perfection pattern digger heads have unique "clamshell" heads for digging in sandy, loamy, loosely-packed soils.



Photo No.	Model	Quality Level	Description	Head Color	Point Spread	Handle	Grip	UPC	Pack Qty.	Pack Wgt.	Pack Cube
1	DG-11	Best	Hercules digger	Blue	6.25"	4' hardwood	—	0 31365 01060 1	2	21.0	1.27
	DG-116	Best	Hercules digger	Blue	6.25"	6' hardwood	—	0 31365 01080 9	2	25.7	1.79
	DG-118	Best	Hercules digger	Blue	6.25"	8' hardwood	—	0 31365 01100 4	2	27.6	2.31
2	DG-11FG	Best	Hercules digger	Clear	6.25"	4' fiberglass	Vinyl	0 31365 01601 6	2	23.4	1.27
3	PD48	Best	Structron Hercules digger	Clear	6.25"	4' fiberglass	Cushion	0 36723 00110 9	2	21.6	1.27
4	DG-15	Best	Lonestar Hercules digger	Blue	6.25"	4' steel	—	0 31365 01190 5	2	32.4	1.44
5	DG-16	Best	Buckeye digger	Blue	6.5"	4' steel	—	0 31365 01200 1	2	32.0	1.26
6	DG-12	Best	Perfection digger	Blue	5.5"	4' hardwood	—	0 31365 01130 1	2	17.2	1.87
	DG-126	Best	Perfection digger	Blue	7.25"	6' hardwood	—	0 31365 01150 9	2	21.0	2.47
	DG-128	Best	Perfection digger	Blue	7.25"	8' hardwood	—	0 31365 01170 7	2	25.0	3.07
7	DG-12FG	Best	Perfection digger	Clear	7.25"	4' fiberglass	Vinyl	0 31365 01603 0	2	19.6	1.87



Posthole diggers and replacement handles



1
DG-14



2
DG-18



3
DG-100H

Eureka pattern diggers feature half-round "split" hardwood handles that provide a single-handle gripping area when digging.

Gibbs diggers combine a single blade with hinge action that acts like a bucket to bring loose soil to the surface.

SEYMOUR
STRUCTRON
THE WORLD'S BEST TOOLS



Photo No.	Model	Description	Head Color	Point Spread	Handle	UPC	Pack Qty.	Pack Wgt.	Pack Cube
1	DG-14	Eureka digger, half-round hardwood handles	Blue	6	4' hardwood	0 31365 01180 6	2	17.4	1.02
2	DG-18	Gibbs digger, single blade action	Blue	—	4.5' hardwood	0 31365 01210 0	2	21.4	2.30
	DG-186	Gibbs digger	Blue	—	6' hardwood	0 31365 01214 2	2	22.8	3.47
	DG-188	Gibbs digger	Blue	—	8' hardwood	0 31365 01214 8	2	30.2	4.51
	DG-10H	Replacement wood handle for DG-10, DG-11, DG-12	—	—	4' hardwood	0 31365 01001 4	12	22.8	0.58
3	DG-100H	Replacement wood handle for DG-100, DG-75	—	—	4' hardwood	0 31365 01002 1	12	22.8	0.52
	FG-11H	Replacement fiberglass handle for DG-100FG	—	—	4' fiberglass	0 31365 01311 4	12	16.6	0.52
	FG-48H	Replacement fiberglass handle for DG-11FG	—	—	4' fiberglass	0 31365 01312 1	12	17.7	0.52
	DG-14H	Replacement wood handle for DG-14	—	—	4' hardwood	0 31365 01003 8	12	20.0	0.72
	PD48H	Replacement fiberglass handle for PD48	—	—	4' fiberglass	0 36723 13474 6	12	26.0	0.50

Augers



Iwan augers are general purpose design for use in a variety of soils. Steel blades are riveted to tough malleable iron yoke. Steel shaft with a welded steel tee handle.

Adjustable Iwan augers will bore holes of varying diameters.

The tree feeding auger bores a 2" diameter hole for applying plant food and water to roots.

The Digwell auger has a telescoping steel handle for a total working length up to 8'6". The square steel extension is dimpled at 7" intervals for locking in settings.

Photo No.	Model	Description	Head Color	Point Spread	Handle	UPC 0 31365 +	Pack Qty.	Pack Wgt.	Pack Cube
1	AU-S2	Iwan auger, steel head/shaft	Blue	2"	Hardwood	02010 5	2	9.8	0.12
1	AU-S3	Iwan auger, steel head/shaft	Blue	3"	Hardwood	02030 3	2	12.6	0.39
1	AU-S4	Iwan auger, steel head/shaft	Blue	4"	Hardwood	02040 2	2	13.6	0.46
1	AU-S6	Iwan auger, steel head/shaft	Blue	6"	Hardwood	02060 0	2	15.2	1.08
1	AU-S8	Iwan auger, steel head/shaft	Blue	8"	Hardwood	02080 8	2	18.0	1.98
1	AU-S10	Iwan auger, steel head/shaft	Blue	10"	Hardwood	02100 3	2	21.6	2.75
1	AU-S12	Iwan auger, steel head/shaft	Blue	12"	Hardwood	02110 2	1	22.1	4.00
2	AU-A1	Adjustable Iwan auger, steel head/shaft	Blue	4", 5", 6"	Hardwood	02130 0	2	15.6	1.08
2	AU-A2	Adjustable Iwan auger, steel head/shaft	Blue	6", 7", 8"	Hardwood	02140 9	2	18.2	1.94
3	AU-02T	Tree feeding auger, 36" steel shaft	Blue	2"	Steel, welded	02200 0	6	22.6	1.50
	AU-1AH	Replacement wood handle for Iwan augers (except AU-S12)	—	—	Hardwood	02230 7	6	4.8	0.12
	AU-2AH	Replacement handle for AU-S12	—	—	—	02234 5	1	1.0	0.12
4	DW-D1	Digwell auger, 5' steel shaft telescopes to 9'	Blue	8" to 14"	Hardwood	02240 6	1	28.0	2.43
	AU-1AX	Auger extension shaft for AU-S3 to AU-10, AU-A1, AU-A2	—	—	—	02231 4	1	5.2	0.19

STRUCTRON® brand extension handles



Fiberglass handle: Safety yellow reinforced fiberglass handles make Structron Superhandles strong, lightweight, and extremely durable.

STĀ-LOK® positive locking system: Patented design allows for variable locking position with maximum locking power.

Threaded metal tip: Solid aluminum-zinc alloy casting for greater strength. Standard 3/4" - 5 Acme thread design.

Microshield® surface: This non-stick surface, unique to Structron Superhandles, resists paint build-up for easier clean-up.

ProGrip™ comfort grip: Features double-wall construction for increased durability. Non-slip finish for a more secure hold.

SUPERHANDLE® 2000 DUAL LOCKING SYSTEM EXTENSION HANDLE

The world's first extension handle with two locking systems to ensure the most secure handle lock available today. Built to industrial quality standards for outstanding performance and durability.

Two-piece grip: Double-wall construction for increased durability. Features non-slip finish for a secure and comfortable hold.

Aluminum tip is strong and lightweight.



EXTERNAL LOCK: Screw down threaded collar to secure handle in any position. Comfortable ergonomic design.

INTERNAL LOCK: Twist inner pole with STĀ-LOK® positive locking system until it snaps into locking position to quickly secure handle at any length.

Photo No.	Model	Quality Level	Description	Extension Length	No. Sections	Lock Type	Grip	UPC 0 36723 +	Pack Qty.	Pack Wgt.	Pack Cube
1	SE12	Best	Superhandle II	1' to 2'	2	STĀ-LOK*	Cushion	00212 0	6	5.0	0.23
	SE24	Best	Superhandle II	2' to 4'	2	STĀ-LOK*	Cushion	00224 3	6	9.2	0.42
	SE48	Best	Superhandle II	4' to 8'	2	STĀ-LOK*	Cushion	00248 9	6	14.8	0.74
	SE612	Best	Superhandle II	6' to 12'	2	STĀ-LOK*	Cushion	02612 6	6	20.5	1.08
	SE816	Best	Superhandle II	8' to 16'	2	STĀ-LOK*	Cushion	02816 8	6	25.6	1.39
	SE824	Best	Superhandle II	8' to 24'	3	STĀ-LOK*	Cushion	02824 3	3	22.5	0.87
2	CE24	Best	Superhandle	2' to 4'	2	Collar	Cushion	00124 6	6	7.2	0.42
	CE48	Best	Superhandle	4' to 8'	2	Collar	Cushion	00148 2	6	12.6	0.74
	CE612	Best	Superhandle	6' to 12'	2	Collar	Cushion	01612 7	6	18.6	1.08
	CE816	Best	Superhandle	8' to 16'	2	Collar	Cushion	01816 9	6	23.7	1.39
3	SS48	Best	Straight handle with metal tip	1" x 48"	1	---	---	01248 8	6	6.4	0.41
	SS60	Best	Straight handle with metal tip	1" x 60"	1	---	---	00260 1	6	7.8	0.51
	SS72	Best	Straight handle with metal tip	1" x 72"	1	---	---	00272 4	6	9.1	0.61



STRUCTRON® brand brooms and squeegees

1
TT1



Tapered tip: Universal friction tip fits all squeegees and other non-threaded cleaning tools. Accepts 3/4" - 5 Acme thread. Unique 8 channel design for secure friction fit.

2
PB24



3
PB24R



5
SS48



4
SB24R



6
IC24
IC36

SUPERIOR HEAVY-DUTY TOOLS
STRUCTRON®



Steel merchandiser holds up to 16 brooms in only 3 sq. ft. of floor space.

Structron brand brooms feature LokBlok™, a threadless locking system that will not loosen during use.

Brooms are available with rough or smooth polypropylene bristles and ProGrip™ comfort grips.



Squeegee/scrapers feature industrial quality black powder-coated steel scraper heads and replaceable Neoprene blades. Extra-strong 60" fiberglass handles with ProGrip™ comfort grips.

Photo No.	Model	Quality Level	Description	Head	Handle	Grip	UPC 0 36723 +	Pack Qty.	Pack Wgt.	Pack Cube
1	TT1	Best	Tapered tip, 4.5"	—	—	—	15009 8	6	1.0	0.04
2	PB24	Best	Push broom for smooth surfaces	3" x 24" with 3" trim	60" fiberglass	Cushion	00324 0	4	14.6	3.28
3	PB24R	Best	Push broom for rough surfaces	3" x 24" with 3" trim	60" fiberglass	Cushion	00424 7	4	14.3	3.28
4	SB24R	Best	Street broom	3" x 24" with 4.5" trim	60" fiberglass	Cushion	00624 1	4	12.5	3.28
5	SS48	Best	Utility handle/Broom handle	—	1" x 48" fiberglass	—	01248 8	6	6.4	0.41
5	SS60	Best	Utility handle/Broom handle	—	1" x 60" fiberglass	—	00260 1	6	7.8	0.51
5	SS72	Best	Utility handle/Broom handle	—	1" x 72" fiberglass	—	00272 4	6	9.1	0.61
6	IC24	Best	Floor squeegee/scrapper	24" x 2.5"	60" fiberglass	Cushion	15002 9	2	7.5	5.90
6	IC36	Best	Floor squeegee/scrapper	36" x 2.5"	60" fiberglass	Cushion	15003 6	2	9.7	8.80

Snow tools and scrapers

Snow pushers are designed to push snow rather than lift and throw it. They allow the user to stand erect to minimize back strain and reduce fatigue.

Snow scoops, often called snow shovels, are designed to lift and throw snow.

Roof rakes are designed to remove snow, wet leaves, and other debris from roofs. They help prevent ice build-up and save costly repairs.



* NEW FOR CATALOG

Photo No.	Model	Quality Level	Description	Head Style	Head size W x H	Handle	Grip	UPC	Pack Qty.	Pack Wgt.	Pack Cube
1 *	PSE200	Best	Snow scoop, ergonomic handle	ABS	18" x 13.5"	34" steel	Poly D	0 36723 11402 1	4	16.6	6.50
2 *	AP100	Best	Snow pusher w/ wear strip	Aluminum	24" x 12"	42" fiberglass	Poly D	0 36723 12380 1	4	19.2	6.89
3 *	AS200	Best	Snow shovel w/ wear strip	Aluminum	18" x 12"	41" fiberglass	Poly D	0 36723 12382 5	4	15.6	2.94
4 *	SP100	Best	Snow pusher w/ wear strip	Steel	24" x 12"	42" fiberglass	Poly D	0 36723 12381 8	4	27.6	6.89
5 *	SS200	Best	Snow shovel	Steel	18" x 12"	41" fiberglass	Poly D	0 36723 12383 2	4	21.2	2.94
6 *	SV-SP22	Better	Snow pusher w/ wear strip	Aluminum	24" x 12"	42" hardwood	Poly D	0 31365 12380 6	4	18.6	6.32
7 *	SV-SS22	Better	Snow shovel w/ wear strip	Aluminum	18" x 12"	41" hardwood	Poly D	0 31365 12382 0	4	15.2	3.75
8 *	SV-SP25	Better	Snow pusher	Steel	24" x 12"	42" hardwood	Poly D	0 31365 12381 3	4	26.6	6.32
9 *	SV-SS25	Better	Snow shovel	Steel	18" x 12"	41" hardwood	Poly D	0 31365 12383 7	4	21.0	3.75
10 *	RR-25X	Best	Roof rake w/ telescoping handle	Aluminum	22" x 5.5"	4 sections	---	0 31365 00100 5	1	5.1	0.53

Snow tools and scrapers

SC-10 scraper: Good quality with promotional price point. Features a straight hardwood handle and a 2-piece steel ferrule.

SC-20 scraper: Professional quality with a tough malleable cast iron socket, high carbon blade, and contoured hardwood handle.

SC-30 scraper: Industrial quality with a 1-piece forged head and socket and a contoured hardwood handle.

SW7 scraper: Industrial quality with a 1-piece forged head and a rugged Structron fiberglass handle.

IC-30 ice chisel: Features a heavy-duty blade designed to chop and break even thick ice.

Scrapers are used for chipping and breaking ice on walks and drives as well as for general clean-up on construction sites and farms.

Ice chisels are heavy-duty tools designed specifically to chop and break ice.

Snow pushers are designed to push snow rather than lift and throw it. They allow the user to stand erect to minimize back strain and reduce fatigue.

Snow scoops, often called snow shovels, are designed to lift and throw snow.

Roof rakes are designed to remove snow, wet leaves, and other debris from roofs. They help prevent ice build-up and save costly repairs.

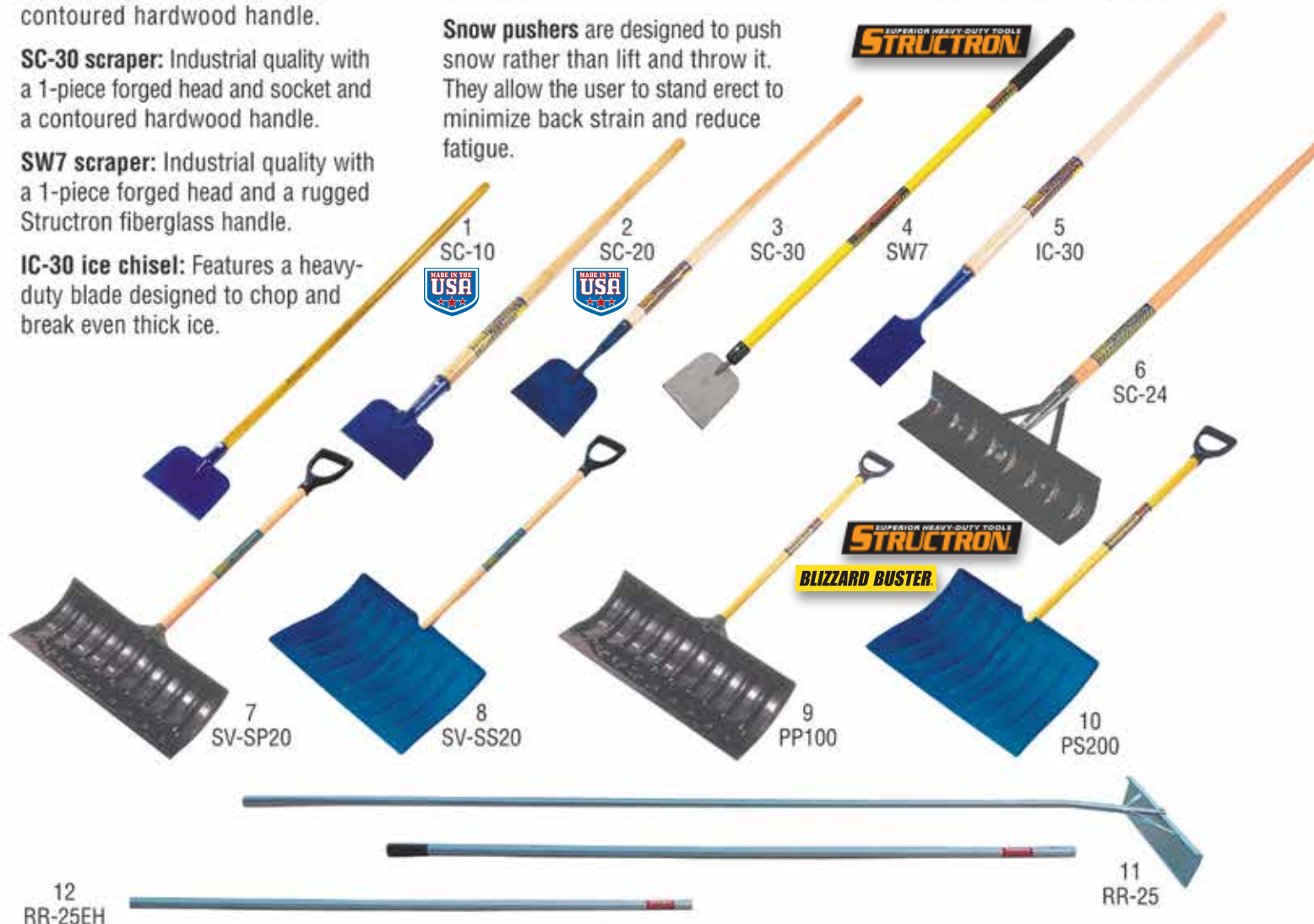

Photo No.	Model	Quality Level	Description	Head Style	Head size W x H	Handle	Grip	UPC	Pack Qty.	Pack Wgt.	Pack Cube
1	SC-10	Good	Scraper	Welded	7" x 5"	48" hardwood	—	0 31365 01500 2	2	4.0	0.48
2	SC-20	Better	Scraper	Riveted	7" x 5"	48" hardwood	—	0 31365 01510 1	2	6.4	0.56
3	SC-30	Best	Scraper	Forged	7" x 6"	54" hardwood	—	0 31365 01520 0	2	7.4	0.66
4	SW-7	Best	Scraper	Forged	7" x 6"	51" fiberglass	Cushion	0 36723 01102 3	4	12.0	0.58
5	IC-30	Best	Ice chisel	Forged	3.5" x 6"	48" hardwood	—	0 31365 01530 9	2	6.3	0.20
6	SC-24	Better	Barn scraper	Steel	24" x 7"	60" hardwood	—	0 31365 01522 4	1	7.0	0.54
7	SV-SP20	Better	Snow pusher	Black poly	12" x 24"	44" hardwood	Poly D	0 31365 12378 8	6	24.9	11.20
8	SV-SS20	Better	Snow shovel	Blue poly	13.5" x 18"	44" hardwood	Poly D	0 31365 12372 1	6	23.6	8.06
9	PP100	Best	Snow pusher	Black ABS	12" x 24"	44" fiberglass	Poly D	0 36723 11300 0	4	15.0	9.55
10	PS200	Best	Snow shovel	Blue ABS	13.5" x 18"	44" fiberglass	Poly D	0 36723 11400 7	4	16.0	6.07
11	RR-25	Better	Roof rake	Aluminum	22" x 5.5"	16' 3-pc. aluminum	Vinyl	0 31365 12913 6	1	5.7	0.42
12	RR-25EH	Better	RR-25 extension handle	—	—	5' aluminum	—	0 31365 12914 3	1	1.4	0.06

Contractor tools - Concrete, asphalt, and drain cleaning

SEYMOUR

THE WORLD'S BEST TOOLS!

STRUCTRON

The CM-30 concrete come-along features an 8" steel ferrule for strength and easy clean-up.

The MH-10 mortar hoe and AR-30 asphalt rake both have a long steel ferrule to provide extra strength and easy clean-up.

The AR-30 asphalt rake features a rugged 1/2 inch square shank for extra rigidity.

The AL-36 asphalt lute blade features notched tooth design for fast placement of asphalt, concrete, and other coarse materials and a smooth blade top for floating.



Photo No.	Model	Description	Head	Head size W x H	Handle	Grip	UPC	Pack Qty.	Pack Wgt.	Pack Cube
1	CM-30	Come-along	Steel with hook	20" x 4.25"	63" hardwood	—	0 31365 12900 6	2	11.2	6.92
2	CC20	Come-along	Steel with hook	20" x 4"	60" fiberglass	Cushion	0 36723 11200 3	2	9.0	0.59
3	CC20A	Come-along	Aluminum	20" x 4"	60" fiberglass	Cushion	0 36723 12200 2	2	6.6	0.50
4	MH-20	Mortar hoe	Steel with mortar mixing holes	7" x 4.75"	54" hardwood	—	0 31365 12902 0	3	12.3	2.63
5	MH-30	Mortar hoe	Steel with mortar mixing holes	10" x 6"	66" hardwood	—	0 31365 12901 3	6	25.4	5.70
6	MH10	Mortar hoe	Forged steel with mortar mixing holes	10" x 6"	66" fiberglass	Cushion	0 36723 00810 8	4	13.3	3.89
7	AL-36A	Asphalt lute	Aluminum	36" x 4"	82" aluminum	—	031365 12904 4	1	5.4	0.39
8	AL36	Asphalt lute	Aluminum	36" x 4.5"	76" fiberglass	Cushion	036723 00536 7	2	10.8	12.37
9	AR-30	Asphalt rake	Forged steel 14-tine	15.5" x 3.75"	60" hardwood	—	0 31365 12903 7	6	39.6	4.56
10	DR-DC4	Drain cleaner	Steel	4" x 15"	72" hardwood	—	0 31365 03010 4	2	13.9	1.39
10	DR-DC5	Drain cleaner	Steel	5" x 15"	72" hardwood	—	0 31365 03020 3	2	14.8	1.87
	DR-1DCH	Replacement hdl for DR-C4-C5	—	—	72" hardwood	—	0 31365 03000 5	1	2.3	0.07

Contractor tools - Roofing, stoning and probes

Level head rakes have teeth designed to gather small weeds and straw. They are also ideal for raking small clods and for seedbed preparation while the flat side is used for leveling.

The SR-30 stone rake features a forged head with 14 heavy-duty straight teeth for spreading stone and other materials with a push-pull action.

The SG1 asphalt shingle remover is a professional quality tool that makes shingle and nail removal easier. Features an extra-strong steel brace and carbon steel skid plate. The 9" serrated steel blade is replaceable.

Roofing spades have a heavy-duty fulcrum welded to the back of the blade for leverage.

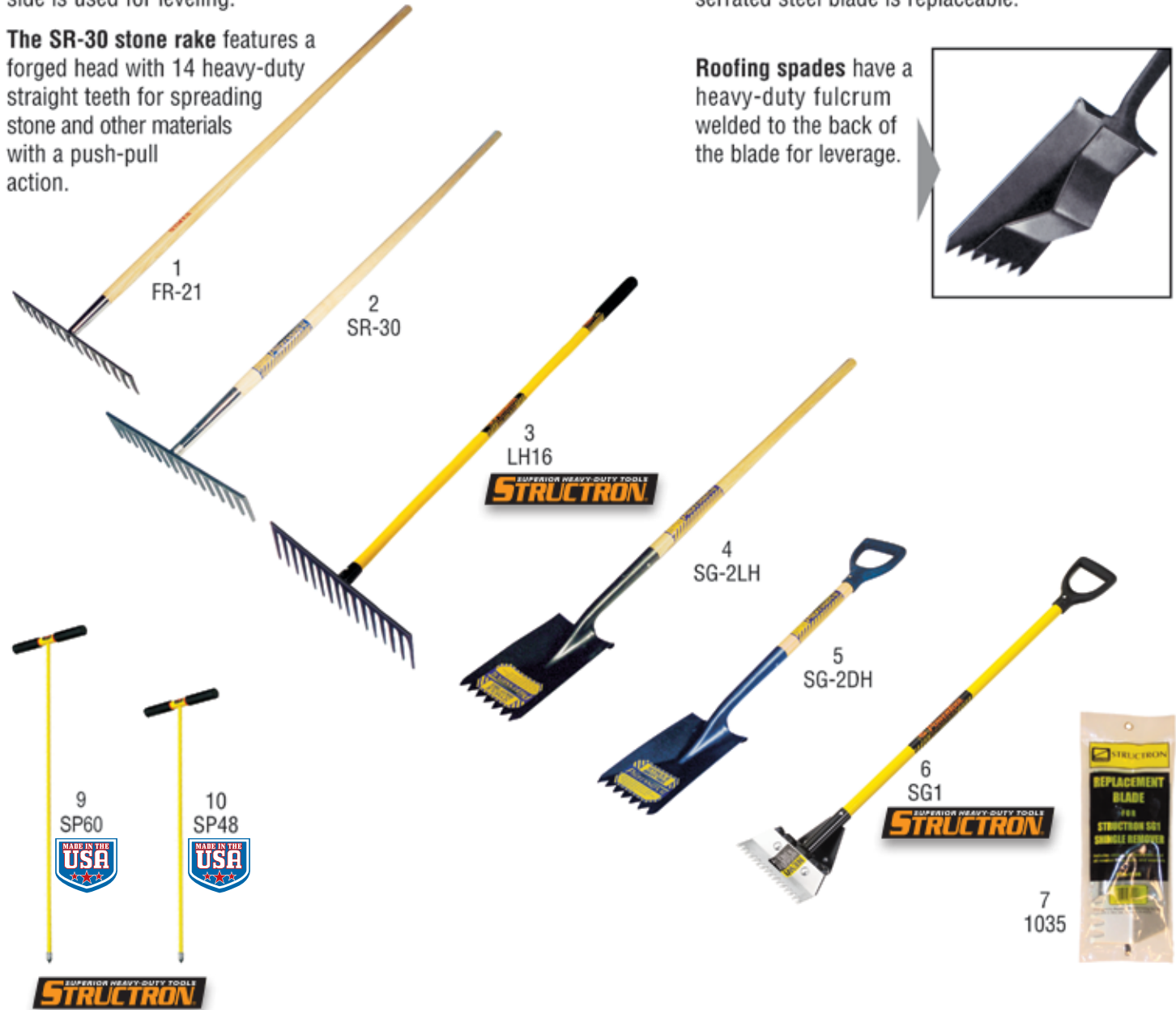

* NEW FOR CATALOG

Photo No.	Model	Quality Level	Description	Head Style	Head size W x H	Handle	Grip	UPC	Pack Qty.	Pack Wgt.	Pack Cube
1	FR-21	Better	Level head rake	14-tine	15.25" x 3.25"	60" hardwood	—	0 31365 12515 2	6	18.8	4.73
2	SR-30	Best	Stone rake, forged head	14-tine	15.5" x 3.75"	66" hardwood	—	0 31365 12520 6	6	29.4	9.86
3	LH16	Best	Level head rake	16-tine	16" x 3.25"	64" fiberglass	Cushion	0 36723 00317 2	4	12.2	2.95
4	SG-2LH	Better	Roofing spade	Notched, fulcrum	7" x 11"	48" hardwood	—	0 31365 01533 0	6	28.5	3.28
5	SG-2DH	Better	Roofing spade	Notched, fulcrum	7" x 11"	29" hardwood	Poly D	0 31365 01532 3	6	27.8	2.14
6	SG1	Best	Shingle remover	Steel, notched	9" wide"	36" fiberglass	Poly D	036723 50001 5	2	11.5	1.88
7	1035	Best	SG1 blade kit	Blade & skid plate	—	—	—	0 36723 80001 6	6	8.3	0.18
9 *	SP60	—	Soil probe	Cast metal	—	60" fiberglass	T-cushion	0 36723 00913 6	4	6.8	1.96
10	SP48	—	Soil probe	Cast metal	—	48" fiberglass	T-cushion	0 36723 00911 2	4	6.0	1.60

Wheelbarrows



Rugged poly wheel with ball bearings for longer life.

1
WB-4S

Heavy gauge seamless steel tray for contractor applications.



2
WB-6S

Our heaviest gauge seamless steel tray for heavy-duty contractor applications.



3
WB-6SHD

Knobby 4-ply tire for better traction, longer wear, and greater puncture resistance.

Cross braces improve lateral strength and stability.



4
WB-6SHDS

Strong steel handles.

Flat-free tire.



5
WB-6P

Heavy-duty channel steel front braces for added strength when carrying heavy loads.



7
WB-JR

Corrosion proof high-density poly trays for heavy-duty contractor and landscaping applications.



6
WB-10P

Dual wheels for added stability when carrying heavy loads.

Steel shoes provide added support and help prevent wear.



8
WB-JRB



Steel rack uses space efficiently to display 3 wheelbarrows.

Seamless steel trays with enamel finish provide excellent durability.

High-density poly trays are corrosion proof and lightweight.

Ball bearings with grease fittings (zirts) for easier rolling and longer life.

Pneumatic 2-ply tires for greater maneuverability.

Front tray braces and bottom cross braces provide added support, strength and stability.

Steel leg shoes provide added stability and longer life.

Rugged hardwood handles are seal coated for maximum moisture and weather resistance.

* NEW FOR CATALOG

Photo No.	Model	Description	Tray Type	Wheel	Tire	Braces	Handle	UPC 0 31365 +	Pack Qty.	Pack Wgt.	Pack Cube
1	WB-4S	4 cu ft wheelbarrow	Steel	Poly, ball bearings	14" 2-ply		Hardwood	12915 0	1	24.0	5.62
2	WB-6S	6 cu ft wheelbarrow	Steel	Steel, ball bearings, zirt	16" 2-ply	Front tray, cross	Hardwood	12919 8	1	43.1	7.76
3	WB-6SHD	6 cu ft wheelbarrow	Steel	Steel, ball bearings, zirt	16" 4-ply knobby	Front tray, cross	Hardwood	12918 1	1	46.4	7.76
4	WB-6SHDS	6 cu ft wheelbarrow	Steel	Steel, ball bearings, zirt	16" flat-free	Front tray, cross	Steel	12930 3	1	49.5	7.76
5	WB-6P	6 cu ft wheelbarrow	Poly	Steel, ball bearings, zirt	16" 2-ply	Front tray, cross	Hardwood	12916 7	1	32.7	8.12
6	WB-10P	10 cu ft wheelbarrow	Poly	Steel, ball bearings, zirt	Two 16" 2-ply	Front tray, cross	Hardwood	12920 4	1	46.0	19.41
7	WB-JR	Children's wheelbarrow	Poly	Poly, ball bearings	Solid rubber	Front tray	Hardwood	12929 7	1	9.8	2.30
8 *	WB-JRB	Children's wheelbarrow, boxed	Poly	Poly, ball bearings	Solid rubber	Front tray	Hardwood	12931 0	1	10.2	2.66

PREMIUM GRADE STRIKING TOOLS Hammers

Cross peen (blacksmith) hammers are used to strike and shape and bend unhardened metal. Also used to shape block, brick, and stone.



Drilling (hand drill) hammers are used to strike cold chisels, punches, star drills, brick chisels, and hardened nails. They are designed to deliver heavy blows with limited swing in tight spaces.



Engineers hammers (short handle sledges) are used to strike stone, concrete, metal, and wood. Often used to drive stakes and rods or move timbers. Short handles allow work in tight spaces.



- ❖ Chamfered edges
- ❖ Shock-absorbing American hickory or premium Structron fiberglass handles
- ❖ Hickory handles are turned-style for better contours and grips

* NEW FOR CATALOG

No.	Model	Description	Head	Handle	UPC 0 31365 +	Pack qty.	Pack wgt.	Pack cube	REPLACEMENT HANDLE LINK #
1	HB-2	Cross peen hammer	2 lbs.	16" hickory	00038 1	6	15.6	0.43	LK-407-19
1	HB-3	Cross peen hammer	3 lbs.	16" hickory	00039 8	6	21.6	0.43	LK-409-19
1	HB-4	Cross peen hammer	4 lbs.	16" hickory	00040 4	6	27.6	0.43	LK-423-19
2	HB-2FG	Cross peen hammer	2 lbs.	16" fiberglass	00041 1	6	16.9	0.43	LK-423-99
2	HB-3FG	Cross peen hammer	3 lbs.	16" fiberglass	00042 8	6	22.9	0.43	LK-423-99
2	HB-4FG	Cross peen hammer	4 lbs.	16" fiberglass	00043 5	6	28.9	0.43	LK-423-99
3	HD-2	Drilling hammer	2 lbs.	10-1/2" hickory	00028 2	6	15.0	0.43	LK-480-19
3	HD-3	Drilling hammer	3 lbs.	10-1/2" hickory	00075 6	6	21.0	0.43	LK-480-19
3	HD-4	Drilling hammer	4 lbs.	10-1/2" hickory	00076 3	6	27.0	0.43	LK-480-19
4	HD-3FG	Drilling hammer	3 lbs.	10-1/2" fiberglass	00029 9	6	21.7	0.43	LK-423-99
4	HD-4FG	Drilling hammer	4 lbs.	10-1/2" fiberglass	00030 5	6	27.7	0.43	LK-423-99
5	HE-2	Engineer hammer	2 lbs.	16" hickory	00020 6	6	15.6	0.43	LK-421-19
5	HE-3	Engineer hammer	3 lbs.	16" hickory	00021 3	6	21.6	0.43	LK-423-19
5	HE-4	Engineer hammer	4 lbs.	16" hickory	00022 0	6	27.6	0.43	LK-423-19
7	* HE-6	Engineer hammer	6 lbs.	16" hickory	14075 9	4	26.7	0.28	LK-423-19
8	* HE-8	Engineer hammer	6 lbs.	16" hickory	14076 6	4	34.7	0.36	LK-423-19
6	HE-2FG	Engineer hammer	2 lbs.	16" fiberglass	00013 8	6	16.9	0.43	LK-423-99
6	HE-3FG	Engineer hammer	3 lbs.	16" fiberglass	00014 5	6	22.9	0.43	LK-423-99
6	HE-4FG	Engineer hammer	4 lbs.	16" fiberglass	00015 2	6	28.9	0.43	LK-423-99

Striking tools - Sledge hammers

Double face sledge hammers are used to strike stone, concrete, metal, and wood. Often used to drive stakes and posts, move timbers, and break concrete.



1

SH-6 SH-12
SH-8 SH-16
SH-10 SH-20W



3

SH-8P



Chamfered edges prevent edges from chipping off for added safety



2

SH-6FG SH-12FG
SH-8FG SH-16FG
SH-10FG SH-20FG

Structron premium fiberglass handles feature a solid fiberglass core with a double-injected molded polypropylene cover for the ultimate in durability for striking tools.

- ❖ Chamfered edges
- ❖ Shock-absorbing American hickory or premium Structron fiberglass handles
- ❖ Hickory handles are turned-style for better contours and grips

* NEW FOR CATALOG

No.	Model	Description	Head	Handle	UPC 0 31365 +	Pack qty.	Pack wgt.	Pack cube	REPLACEMENT HANDLE LINK #
1	SH-6	Sledge hammer	6 lbs.	36" hickory	00023 7	4	28.6	0.59	LK-001-19
1	SH-8	Sledge hammer	8 lbs.	36" hickory	00024 4	4	36.6	0.68	LK-001-19
3	* SH-8P	Promo sledge hammer	8 lbs.	36" hickory	00079 4	4	32.0	0.95	LK-001-19
1	SH-10	Sledge hammer	10 lbs.	36" hickory	00025 1	4	44.6	0.80	LK-001-19
1	SH-12	Sledge hammer	12 lbs.	36" hickory	00026 8	2	26.3	0.46	LK-001-19
1	SH-16	Sledge hammer	16 lbs.	36" hickory	00027 5	2	34.3	0.60	LK-010-19
1	SH-20W	Sledge hammer	20 lbs.	36" hickory	00084 8	2	42.3	0.74	LK-010-19
2	SH-6FG	Sledge hammer	6 lbs.	36" fiberglass	00016 9	4	33.2	0.59	LK-001-99
2	SH-8FG	Sledge hammer	8 lbs.	36" fiberglass	00017 6	4	41.2	0.68	LK-001-99
2	SH-10FG	Sledge hammer	10 lbs.	36" fiberglass	00018 3	4	49.2	0.80	LK-001-99
2	SH-12FG	Sledge hammer	12 lbs.	36" fiberglass	00019 0	2	28.6	0.46	LK-001-99
2	SH-16FG	Sledge hammer	16 lbs.	36" fiberglass	00082 4	2	36.6	0.60	LK-001-99
2	SH-20FG	Sledge hammer	20 lbs.	36" fiberglass	00083 1	2	42.6	0.74	LK-001-99

Striking tools - Axes

Michigan single bit axes are general purpose axes used to fell small trees, split wood, trim branches, and prune trees.

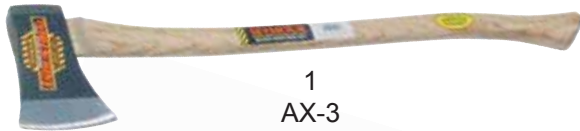

1
AX-3
AX-5



7
AX-3P



2
AX-3FG



Michigan double bit axes are general purpose axes used to fell small trees, split wood, trim branches, and prune trees. Having two bits lengthens the time between blade sharpening.



4
AX-DB3



5
AX-DB3FG



Boys (house) single bit axes are lighter duty axes used to cut saplings, split kindling, trim branches, and prune trees.

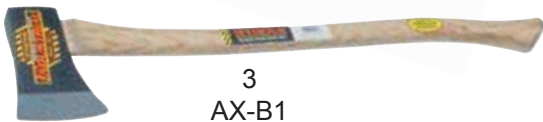

3
AX-B1
AX-B2

Pulaski axes combine a single bit axe blade with a mattock blade. This blade combination makes it ideal for fighting forest fires and for a variety of landscaping applications.

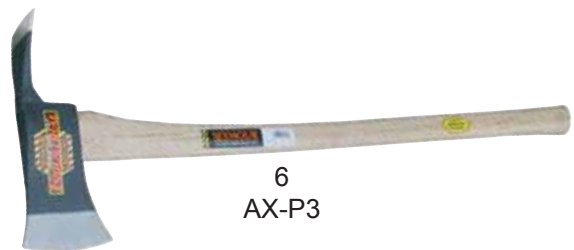

6
AX-P3

- ❖ Polished and beveled edges
- ❖ Shock-absorbing American hickory or premium Structron fiberglass handles
- ❖ Hickory handles are turned-style for better contours and grips

* NEW FOR CATALOG

No.	Model	Description	Head	Handle	UPC 0 31365 +	Pack qty.	Pack wgt.	Pack cube	REPLACEMENT HANDLE LINK #
1	AX-3	Michigan single bit axe	3.5 lbs.	36" hickory	00045 9	4	19.2	0.45	LK-100-19
1 *	AX-5	Michigan single bit axe	5.0 lbs.	36" hickory	00062 6	4	27.4	0.81	LK-100-19
7 *	AX-3P	Promotional axe	3.5 lbs.	36" hickory	00081 7	4	19.0	0.81	LK-100-19
2	AX-3FG	Michigan single bit axe	3.5 lbs.	36" fiberglass	00044 2	4	23.6	0.45	LK-100-19
3	AX-B1	Boys single bit axe	1.25 lbs.	14" hickory	00046 6	4	7.0	0.11	LK-368-19
3	AX-B2	Boys single bit axe	2.25 lbs.	28" hickory	00047 3	4	12.3	0.23	LK-116-19
4	AX-DB3	Michigan double bit axe	3.5 lbs.	36" hickory	00055 8	4	19.4	0.68	LK-140-19
5	AX-DB3FG	Michigan double bit axe	3.5 lbs.	36" fiberglass	00056 5	4	23.6	0.68	LK-140-99
6	AX-P3	Pulaski single bit axe	3.5 lbs.	36" hickory	00074 9	4	19.2	0.77	LK-140-19

Striking tools - Mauls & wedges

Wood splitting (woodchopper) mauls are used to split wood. The blade is designed to split rather than cut, and the heavy sledge-end adds power to the stroke. The sledge-end is also used to drive wood-splitting wedges.

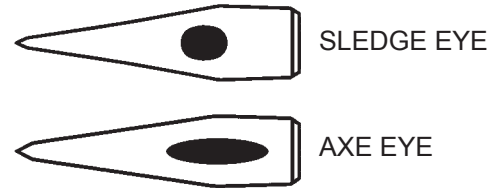

SLEDGE EYE

AXE EYE

Sledge eye and axe eye design

For splitting mauls, sledge eye design is the most widely used while axe eye design is preferred in some regions.

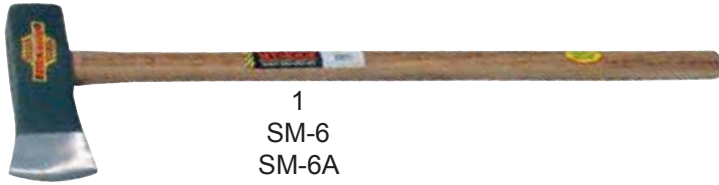

1
SM-6
SM-6A
SM-8
SM-8A



4
SM-6P

SAFETY TIP:

Never hit the sledge-end of a maul with a sledge hammer or another maul.



2
SM-6FG
SM-8FG



Wood-splitting wedges are used to split wood. The steel wedges are struck by sledge hammers and the sledge-end of mauls.

- ❖ Polished and beveled edges
- ❖ Shock-absorbing American hickory or premium Structron fiberglass handles
- ❖ Hickory handles are turned-style for better contours and grips



3
WW-4
WW-5
WW-6

* NEW FOR CATALOG

No.	Model	Description	Head	Handle	UPC 0 31365 +	Pack qty.	Pack wgt.	Pack cube	REPLACEMENT HANDLE LINK #
1	SM-6	Splitting maul, sledge eye	6 lbs.	36" hickory	00033 6	4	28.6	0.70	LK-001-19
1	SM-8	Splitting maul, sledge eye	8 lbs.	36" hickory	00034 3	4	36.6	0.84	LK-001-19
1	SM-6A	Splitting maul, axe eye	6 lbs.	36" hickory	00053 4	4	28.6	0.70	LK-206-19
1	SM-8A	Splitting maul, axe eye	8 lbs.	36" hickory	00054 1	4	36.6	0.84	LK-206-19
4 *	SM-6P	Promo splitting maul, sledge eye	6 lbs.	36" hickory	00078 7	4	28.0	1.06	LK-001-19
2	SM-6FG	Splitting maul, sledge eye	6 lbs.	36" fiberglass	00031 2	4	33.2	0.70	LK-001-99
2	SM-8FG	Splitting maul, sledge eye	8 lbs.	36" fiberglass	00032 9	4	41.2	0.84	LK-001-99
3	WW-4	Wood splitting wedge	4 lbs.	----	00035 0	4	16.5	0.70	----
3	WW-5	Wood splitting wedge	5 lbs.	----	00036 7	4	20.5	0.70	----
3	WW-6	Wood splitting wedge	6 lbs.	----	00037 4	4	24.5	0.70	----

Striking tools - Picks & mattocks

Pick mattocks combine a pick blade with a mattock blade. They are used to dig or grub, especially in hard dirt or clay soils. The pointed pick blade can be used to loosen hard soil while the broader mattock blade is used to dig or remove loose soil.

- ❖ Forged steel heads
- ❖ Shock-absorbing American hickory or premium Structron fiberglass handles
- ❖ Hickory handles are turned-style for better contours and grips



Cutter mattocks combine an axe-like cutter blade with a mattock blade. They are used to chop and dig, especially in hard dirt or clay soils.

The cutter blade can be used to cut roots and loosen hard soil. The mattock blade is used to dig or remove loose soil.

Garden cutter mattocks are light-duty versions of the heavier cutter mattocks. They combine an axe-like cutter blade with a mattock blade. They are used to chop and dig, especially in hard dirt or clay soils.

The cutter blade can be used to cut roots and loosen hard soil. The mattock blade is used to dig or remove loose soil.

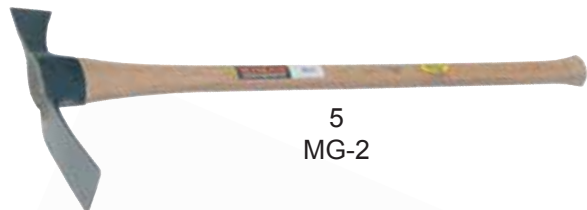
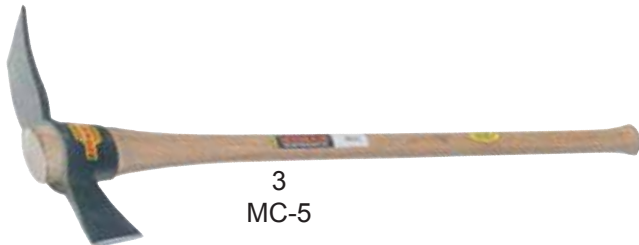

* NEW FOR CATALOG

No.	Model	Description	Head	Handle	Eye size	UPC 0 31365 +	Pack qty.	Pack wgt.	Pack cube	REPLACEMENT HANDLE LINK #
1	MP-5	Pick mattock	5 lbs.	36" hickory	6	00005 3	4	28.4	1.13	LK-220-19
7 *	MP-5P	Promo pick mattock	5 lbs.	36" hickory	6	00080 0	4	24.0	1.27	LK-220-19
2	MP-5FG	Pick mattock	5 lbs.	36" fiberglass	6	00006 0	4	30.4	1.13	LK-220-99
3	MC-5	Cutter mattock	5 lbs.	36" hickory	6	00007 7	4	28.4	1.13	LK-220-19
4	MC-5FG	Cutter mattock	5 lbs.	36" fiberglass	6	00008 4	4	30.4	1.13	LK-220-99
5	MG-2	Garden cutter mattock	2.5 lbs.	36" hickory		00057 2	4	16.4	1.83	LK-200-19
6	MG-2FG	Garden cutter mattock	2.5 lbs.	36" fiberglass		00064 0	4	17.5	1.83	LK-220-99

Striking tools - Picks & mattocks

Garden pick mattocks are light-duty versions of the heavier pick mattocks. They combine a pick blade with a mattock blade. They are used to dig or grub, especially in hard dirt or clay soils.

The pointed pick blade can be used to loosen hard soil while the broader mattock blade is used to dig or remove loose soil.

Railroad (clay) picks combine a pointed pick blade with a pick blade that has a narrow cutting edge. They are used to dig and loosen soil, especially in hard dirt or clay soils.

The pointed pick blade can be used for deeper penetration while the other blade can be used for cutting and digging.



Garden hoe mattocks combine a hoe blade with a mattock blade. They are used to chop, dig or grub.

* NEW FOR CATALOG

No.	Model	Description	Head	Handle	Eye size	UPC 0 31365 +	Pack qty.	Pack wgt.	Pack cube	REPLACEMENT HANDLE LINK #
1	GP-2	Garden pick mattock	2.5 lbs	36" hickory		00065 7	4	16.4	1.83	LK-200-19
2	GP-2FG	Garden pick mattock	2.5 lbs.	36" fiberglass		00066 4	4	17.5	1.83	LK-220-99
3 *	HM-949	Garden hoe mattock	2.0 lbs	51" hardwood		12609 8	6	18.7	3.03	LK-949-21
4	RP-5	Railroad pick	5 lbs.	36" hickory	6	00009 1	4	28.4	0.89	LK-220-19
4	RP-6	Railroad pick	6 lbs.	36" hickory	6	00011 4	4	32.4	0.89	LK-220-19
5	RP-5FG	Railroad pick	5 lbs.	36" fiberglass	6	00010 7	4	30.4	0.89	LK-220-99
5	RP-6FG	Railroad pick	6 lbs.	36" fiberglass	6	00012 1	4	34.4	0.89	LK-220-99
6	PM-5H	Pick mattock, head only	5 lbs.	----	6	00067 1	4	20.8	0.36	----
7	MC-5H	Cutter mattock, head only	5 lbs.	----	6	00068 8	4	20.8	0.36	----
8	RP-5H	Railroad pick, head only	5 lbs.	----	6	00069 5	4	20.8	0.36	----
8	RP-6H	Railroad pick, head only	6 lbs.	----	6	00070 1	4	24.8	0.36	----

Striking tools - Steel bars

San Angelo bars have a chisel head on one end and a diamond point on the other end. They are used to pry and dig.



1
DG-23

Pinch point crow bars have a slanted point. They are used to pry or move heavy objects and to split or separate wood, metal, or concrete forms.



2
DG-PP60

Wedge point crow bars have a wedge-shaped point. They are used to pry or move heavy objects and to split or separate wood, metal, or concrete forms.



3
DG-WP60

Posthole digger bars have a chisel head on one end and a tamper point on the other end. The chisel end is used to dig or loosen soil in postholes. The tamper end is used to pack the soil around posts that have been set in the holes. Also great for moving rocks from soil.

❖ Seymour steel bars are drop forged for superior strength



4
DG-19

Slate bars have a bent chisel head on one end and a diamond point on the other end. The chisel end is used to loosen slate in mines. The diamond point is used as a jack bar on track jacks.

❖ Convenient 1-packs for the longer and heavier bars



5
SB-48
SB-60

Wrecking (gooseneck) bars are used to pull nails and to pry apart wood. They have a nail puller head on the gooseneck end. The gooseneck provides leverage for heavy pulling. The other end has a bent chisel head for prying.



6
WR-12 WR-30
WR-18 WR-36
WR-24

No.	Model	Description	Weight	Size	UPC 0 31365 +	Pack qty.	Pack wgt.	Pack cube
1	DG-23	San Angelo bar	17 lbs.	72" x 1" hex	01221 6	1	17.0	0.07
2	DG-PP60	Pinch point bar	18 lbs.	60" x 1-1/4"	00002 2	1	18.0	0.05
3	DG-WP60	Wedge point bar	18 lbs.	60" x 1-1/4"	00003 9	1	18.0	0.05
4	DG-19	Posthole digger bar	17 lbs.	72" x 1"	01220 9	1	17.0	0.26
5	SB-48	Slate bar	11 lbs.	48" x 1" hex	00058 9	1	11.0	0.09
5	SB-60	Slate bar	14 lbs.	60" x 1" hex	00060 2	1	14.0	0.11
6	WR-12	Wrecking bar	0.75 lbs.	12" x 1/2" hex	00048 0	4	3.0	0.04
6	WR-18	Wrecking bar	1.75 lbs.	18" x 5/8" hex	00049 7	4	7.0	0.06
6	WR-24	Wrecking bar	3.25 lbs.	24" x 3/4" hex	00050 3	4	13.0	0.16
6	WR-30	Wrecking bar	3.75 lbs.	30" x 3/4" hex	00051 0	4	15.0	0.19
6	WR-36	Wrecking bar	4.25 lbs.	36" x 3/4" hex	00052 7	4	17.0	0.23

Striking tools - Scrapers & tampers

SuperScraper™ scraping tools are used to remove ice on walks and drives, remove old flooring and roofing, clean concrete, and for general clean-up on construction sites and farms. These super-duty scrapers are also rugged enough to sever roots and loosen hard-packed soil.



1
SC-48



2
SC-79



3
SC-79D

Tampers are used to compact loose soil, sand, and stone. Often used to prepare foundation beds for drives, walks, and patios.

- ❖ Solid cast iron heads
- ❖ Braced corners
- ❖ Contoured hardwood or premium Structron fiberglass handles



4
TP-30
TP-32



5
TP-8FG



No.	Model	Description	Head	Size	UPC 0 31365 +	Pack qty.	Pack wgt.	Pack cube	REPLACEMENT HANDLE LINK #
1	SC-48	SuperScraper™	4" x 8"	54" hardwood	00071 8	2	8.1	0.26	7219L
2	SC-79	SuperScraper™	7" x 9"	54" hardwood	00072 5	2	11.5	0.45	7219L
3	SC-79D	SuperScraper™	7" x 9"	36" wood, D-grip	00073 2	2	10.8	0.40	7220L
4	TP-30	Tamper, cast iron head	8" x 8"	44" hardwood	12909 9	4	46.6	1.72	7280BL
4	TP-32	Tamper, cast iron head	10" x 10"	44" hardwood	12908 2	4	63.8	1.72	7280BL
5	TP-8FG	Tamper, cast iron head	8" x 8"	44" fiberglass	00063 3	2	23.5	2.28	STR-TP8H

SEYMOUR

THE WORLD'S BEST TOOLS!

STRUCTRON

Made with extra-strong aluminum heads, heavy duty, two-piece braces, and extra long fiberglass handles.



The LR-30W and LR-36A landscape rakes feature colorful point-of-purchase packaging with a vertical space saving design that hangs on single prong hooks. Landscape/field rakes are ideal for raking and leveling.



Fence pliers are packaged in colorful vinyl bags that provide effective pegboard and slatwall merchandising.

Photo No.	Model	Description	Head	Handle	Grip	UPC	Pack Qty.	Pack Wgt.	Pack Cube
1	LR-30W	Landscape rake	30" aluminum with brace	60" hardwood	—	0 31365 12910 5	6	16.8	2.32
2	LR-36A	Landscape rake	36" aluminum with brace	66" aluminum	—	0 31365 12906 8	6	25.8	2.76
3	LR24	Landscape rake	24" aluminum with brace	66" fiberglass	Cushion	0 36723 50024 4	2	7.5	4.72
3	LR36	Landscape rake	36" aluminum with brace	66" fiberglass	Cushion	0 36723 00436 0	2	13.0	7.08
4	TR-30	Thatching rake	20 teeth, 14-3/4"	60" hardwood	—	0 31365 30309 3	2	8.7	2.83
5	2T-1900	Fence pliers	Alloy steel multi-purpose, 10.5"	Forged steel	Vinyl	0 31365 10700 4	6	10.5	0.77
6	2T-110	Fence pliers	Square nose, 10"	Forged steel	Vinyl	0 31365 10701 1	6	6.0	0.14
7	2T-120	Fence pliers	Round nose, 10"	Forged steel	—	0 31365 10702 8	6	6.0	0.14

Scoops

Versatile grain scoops are ideal for moving grain, seed, feed, fertilizer, and other granulated materials. They are also used for snow removal.

General purpose scoops provide handy tools sized between square point shovels and large grain scoops. They are best for moving sand, gravel, asphalt and other loose materials. They can also be used for snow removal, scraping and clean-up.

Coal scoops are designed to efficiently move coal.

SEYMOUR

THE WORLD'S BEST ONLY
STRUCTRON

Head materials: aluminum heads are light weight and rust-free. Poly and ABS heads are light weight, rust-free and durable. Steel heads are the most durable.

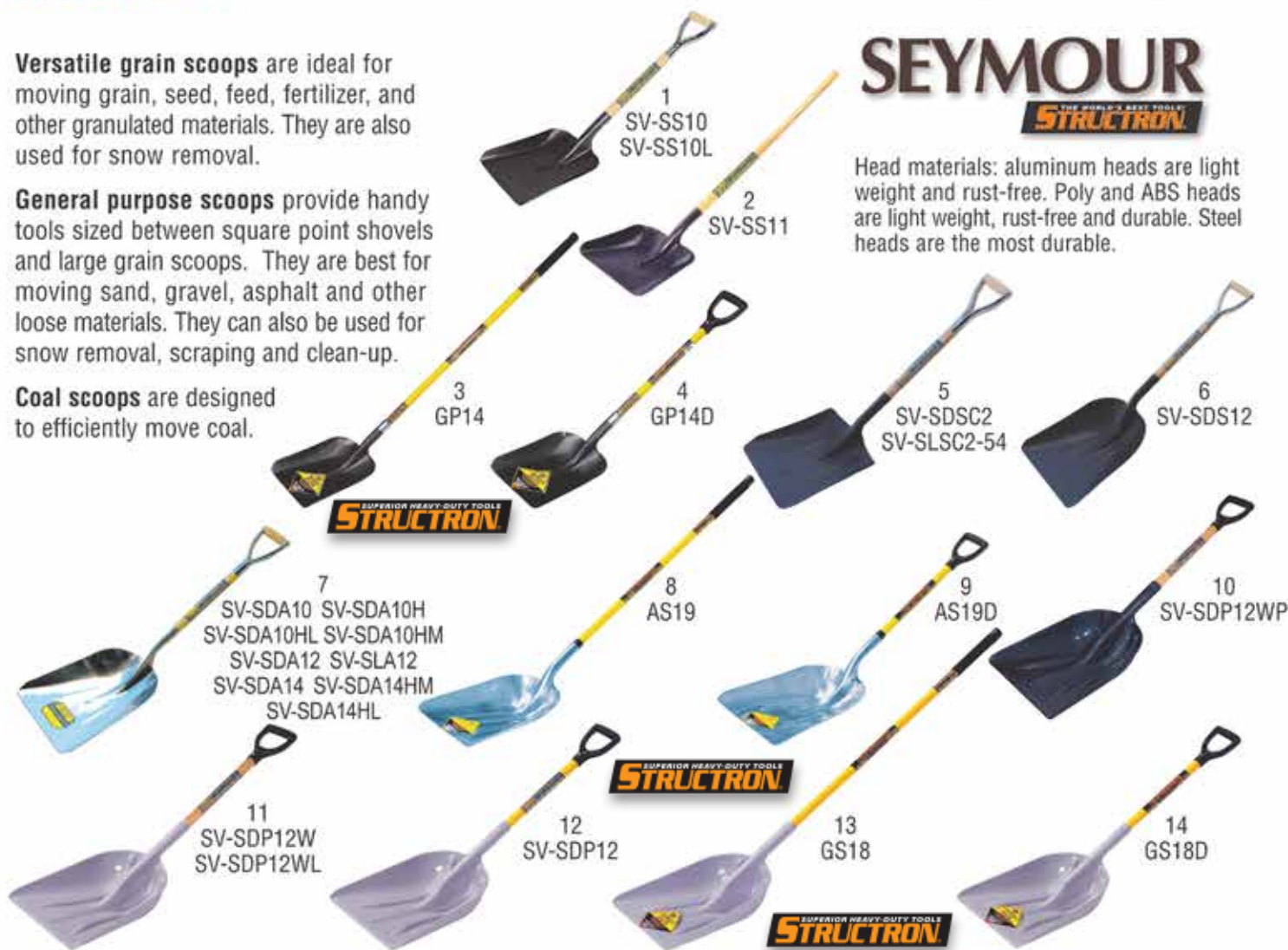

* NEW FOR CATALOG

Photo No.	Model	Quality Level	Description	Head Style	Head size W x H	Handle	Grip	UPC	Pack Qty.	Pack Wgt.	Pack Cube
1	SV-SS10	Good	General purpose scoop	#2 steel	11" x 13.5"	26" hardwood	Steel D	0 31365 12350 9	6	25.2	3.61
1	SV-SS10L	Better	General purpose scoop	#2 steel	11" x 13.5"	36" hardwood	Steel D	0 31365 12363 9	6	30.0	4.52
2	SV-SS11	Good	General purpose scoop	#2 steel	11" x 13.5"	44" hardwood	---	0 31365 23511 0	6	31.2	5.32
3	GP14	Best	General purpose scoop	#2 steel	11" x 13.5"	48" fiberglass	Cushion	0 36723 00316 5	4	20.5	3.39
4	GP14D	Best	General purpose scoop	#2 steel	11" x 13.5"	29" fiberglass	Poly D	0 36723 01316 4	4	17.8	2.34
5	SV-SDSC2	Better	Coal scoop	#2 steel	13.5" x 14.5"	30" hardwood	Steel D	0 31365 12368 4	6	33.9	4.40
5	SV-SLSC2-54	Better	Coal scoop	#2 steel	13.5" x 14.5"	54" hardwood	Steel D	0 31365 12378 3	6	37.4	7.73
6	SV-SDS12	Better	Grain scoop	#12 steel	15" x 19"	30" hardwood	Steel D	0 31365 12369 1	3	45.5	5.61
7	SV-SDA10	Better	Grain scoop	#10 aluminum	14.5" x 18"	30" hardwood	Steel D	0 31365 12367 7	6	23.6	5.69
7 *	SV-SDA10H	Better	Grain scoop	#10 heavy aluminum	14.5" x 18"	29" hardwood	Steel D	0 31365 12348 6	6	24.0	6.74
7 *	SV-SDA10HL	Better	Grain scoop	#10 heavy aluminum	14.5" x 18"	40" hardwood	Steel D	0 31365 12349 3	6	28.8	9.29
7 *	SV-SDA10HM	Better	Grain scoop	#10 heavy aluminum	14.5" x 18"	36" hardwood	Steel D	0 31365 12351 6	6	28.8	8.10
7	SV-SDA12	Better	Grain scoop	#12 aluminum	15.25" x 19"	30" hardwood	Steel D	0 31365 12352 3	6	22.2	6.67
7	SV-SLA12	Better	Grain scoop	#12 aluminum	15.25" x 19"	48" hardwood	Steel D	0 31365 12376 9	6	35.7	9.67
7	SV-SDA14	Better	Grain scoop	#14 aluminum	15.5" x 20"	30" hardwood	Steel D	0 31365 12353 0	6	23.0	7.67
7	SV-SDA14HM	Better	Grain scoop	#14 aluminum	15.5" x 20"	36" hardwood	Steel D	0 31365 12359 2	6	29.1	9.40
7	SV-SDA14HL	Better	Grain scoop	#14 aluminum	15.5" x 20"	40" hardwood	Steel D	0 31365 12358 5	6	31.5	10.33
8	AS19	Best	Grain scoop	#12 aluminum	15.25" x 19"	51" fiberglass	Cushion	0 36723 00609 8	4	14.0	5.64
9	AS19D	Best	Grain scoop	#12 aluminum	15.25" x 19"	29" fiberglass	Poly D	0 36723 01609 7	4	13.3	4.77
10	SV-SDP12WP	Good	Grain scoop	#10 poly	13.5" x 17"	30" hardwood	Poly D	0 31365 12374 5	6	20.3	5.55
11	SV-SDP12W	Better	Grain scoop	#12 ABS	14.25" x 19"	30" hardwood	Poly D	0 31365 12357 8	6	25.0	6.50
11	SV-SDP12WL	Better	Grain scoop	#12 ABS	14.25" x 19"	36" hardwood	Poly D	0 31365 12362 2	6	26.7	7.20
12	SV-SDP12	Better	Grain scoop	#12 ABS	14.25" x 19"	27" fiberglass	Poly D	0 31365 12354 7	6	22.1	5.83
13	GS18	Best	Grain scoop	#12 ABS	14.25" x 19"	51" fiberglass	Cushion	0 36723 00610 4	4	17.0	7.67
14	GS18D	Best	Grain scoop	#12 ABS	14.25" x 19"	29" fiberglass	Poly D	0 36723 15004 3	4	12.4	4.77

Forks



Spading forks are used to work loose soil, aerate sod, dig root crops, and transplant bulbs and plants.

Manure forks are designed to lift manure and other loose material without sifting.

Hay forks are designed to lift and move hay and straw.

Compost forks are best for moving, spreading, and aerating compost.

Bedding forks are designed to remove manure from stock bedding. They are also ideal for spreading mulch, compost, and lifting leaves.

Ensilage forks are used to load silage into vehicles and to offload silage at feeding stalls. They are also used to load and spread mulch.

Barley-straw forks are ideal for spreading straw.

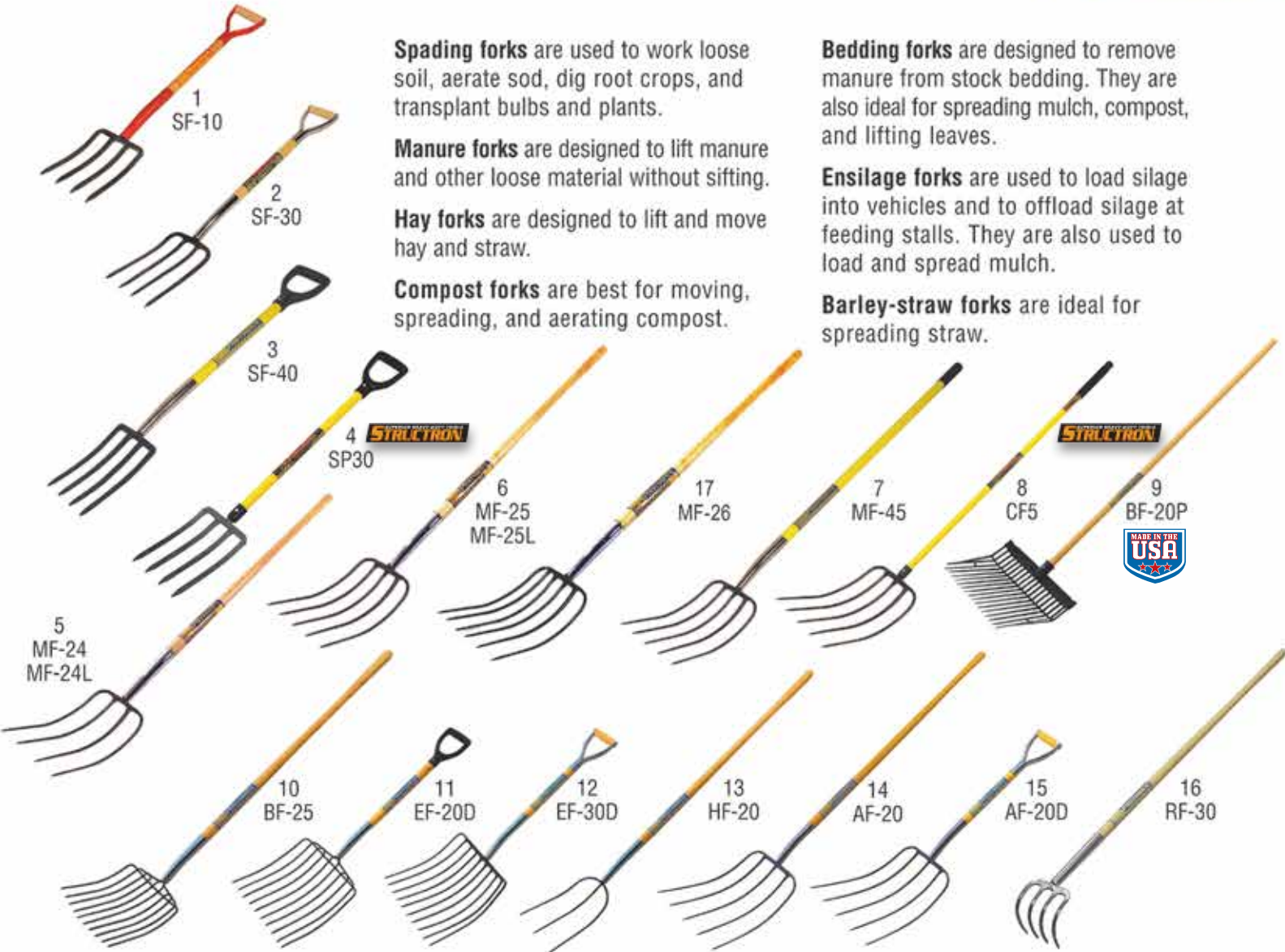

* NEW FOR CATALOG

Photo No.	Model	Quality Level	Description	Head Type	Tines	Head Size W x H	Handle	Grip	UPC	Pack Qty.	Pack Wgt.	Pack Cube
1	SF-10	Good	Spading fork	Forged steel	4	6" x 10"	31" hardwood	Steel D	0 31365 12403 2	6	23.4	1.22
2	SF-30	Best	Spading fork	Forged steel	4	7.25" x 11"	31" hardwood	Steel D	0 31365 12400 1	3	12.6	1.73
3	SF-40	Better	Spading fork	Forged steel	4	6" x 10"	30" fiberglass	Poly D	0 31365 12404 9	3	9.7	0.77
4	SP30	Best	Spading fork	Forged steel	4	7.25" x 11.25"	30" fiberglass	Poly D	0 36723 00910 5	4	14.4	1.53
5	MF-24	Better	Manure fork	Forged steel	4	8.75" x 12"	48" hardwood	—	0 31365 05022 5	3	10.9	2.00
5	MF-24L	Better	Manure fork	Forged steel	4	8.75" x 12"	54" hardwood	—	0 31365 05023 2	3	11.7	2.20
6	MF-25	Better	Manure fork	Forged steel	5	8.75" x 12"	48" hardwood	—	0 31365 05024 9	3	11.2	2.00
6	MF-25L	Better	Manure fork	Forged steel	5	8.75" x 12"	54" hardwood	—	0 31365 05025 6	3	12.2	2.20
17 *	MF-26	Better	Manure fork	Forged steel	6	8.75" x 12"	54" hardwood	—	0 31365 12114 7	3	11.5	2.00
7	MF-45	Better	Manure fork	Forged steel	5	8.75" x 12"	48" fiberglass	Vinyl	0 31365 05021 8	3	11.3	2.60
8	CF5	Best	Compost fork	Forged steel	5	9" x 11.5"	54" fiberglass	Cushion	0 36723 00905 1	4	10.7	2.00
9	BF-20P	Good	Bedding fork	Poly	18	16" x 12"	54" hardwood	—	0 31365 12623 4	3	7.3	6.45
10	BF-25	Better	Bedding fork	Welded steel	10	11" x 12"	48" hardwood	—	0 31365 05028 7	3	13.2	4.12
11	EF-20D	Better	Ensilage fork	Welded steel	10	15" x 15"	30" hardwood	Poly D	0 31365 05031 7	3	18.8	2.78
12	EF-30D	Best	Ensilage fork	Forged steel	10	15.5" x 16"	30" hardwood	Steel D	0 31365 05032 4	3	21.0	3.67
13	HF-20	Better	Hay fork	Forged steel	3	8" x 12"	48" hardwood	—	0 31365 05027 0	3	7.6	1.93
14	AF-20	Better	Barley-straw fork	Forged steel	5	14.5" x 18"	54" hardwood	—	0 31365 05029 4	3	13.5	5.83
15	AF-20D	Better	Barley-straw fork	Forged steel	5	14.5" x 18"	30" hardwood	Steel D	0 31365 05033 1	3	12.7	3.70
16	RF-30	Best	Refuse Fork/potato hook	Forged steel	4	7" x 8.5"	54" hardwood	—	0 31365 05037 9	3	14.7	3.08

Specialty hoes

Eye hoes feature large heavy blades best for heavy-duty digging and cultivating.

Grub hoe blades are narrower than eye hoes for easier and deeper ground penetration.

Italian grape hoes are designed specifically for cultivating and weeding around grape vines.

Hardwood handles for eye hoes, grub hoes, and Italian grape hoes are sold separately.



6 DG-AEH



7 DG-AEH-60



8 DG-IGH



Photo No.	Model	Description	Head size W x H	Handle	UPC 0-31365 +	Pack Qty.	Pack Wgt.	Pack Cube
1	2E-AE0	Eye hoe, American pattern	7.5" x 7"	Sold separately	10380 8	3	6.4	0.16
2	2E-AE1	Eye hoe, American pattern	8" x 7.5"	Sold separately	10390 7	3	6.8	0.16
3	2E-AE2	Eye hoe, American pattern	8.5" x 7.75"	Sold separately	10400 3	3	6.9	0.16
4	2E-G60	Grub hoe	8.5" x 4.5"	Sold separately	10500 0	3	4.8	0.16
5	2E-IG7	Italian grape hoe	10" x 7"	Sold separately	10600 7	3	8.3	0.16
6	DG-AEH	Handle for eye and grub hoes	—	54" circular cross section	01005 2	3	6.3	0.40
7	DG-AEH-60	Handle for eye and grub hoes	—	60" circular cross section	01011 3	3	6.6	0.44
8	DG-IGH	Handle for Italian grape hoe	—	40" oval cross section	01006 9	3	6.3	0.76

Beet hoes or nurserymen's hoes are best for weeding, chopping, and making furrows. The sloping edges enable hoeing close to beet leaves.

Southern meadow hoes, also called blackland or cotton hoes, are used for weeding and chopping.

Warren hoes or cultivator hoes have a triangular shape for making furrows and cultivating between plants. Sharp point enables use close to young seedlings. The "ears" on the back of the head are designed to pull the soil back onto newly planted seeds.



Photo No.	Model	Description	Head size W x H	Handle	UPC 0-31365 +	Pack Qty.	Pack Wgt.	Pack Cube
1	SH-20	Scuffle hoe	6" x 4"	54" hardwood	12599 2	6	14.4	1.86
2	BH-30	Beet hoe, forged head	7" x 3.5"	54" hardwood	12613 5	6	14.6	2.48
2	BH-35	Beet hoe, forged head	7" x 3.5"	60" hardwood	12624 1	6	16.1	2.74
3	WH-30	Warren hoe, forged head	4.75" x 6.25"	54" hardwood	12708 8	6	12.6	2.08
4	SH-36	Southern meadow hoe	3.5" x 6"	60" hardwood	10402 7	6	15.6	2.14
4	SH-37	Southern meadow hoe	3.5" x 7"	60" hardwood	10403 4	6	17.4	2.33
5	BP-20	Bulb planter	3" diameter	30" steel	12598 5	6	16.0	2.45

Lawn & leaf rakes

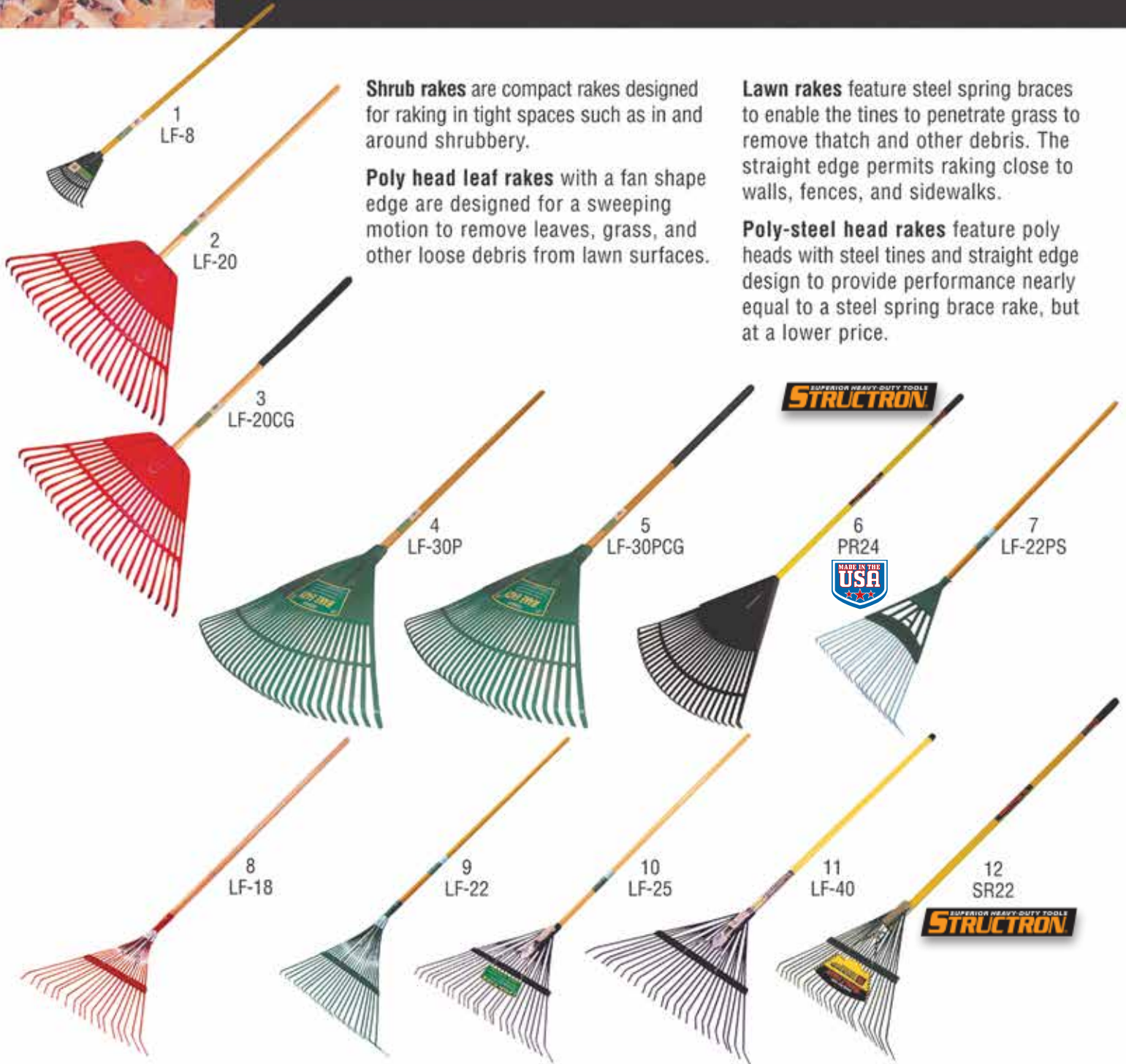

Shrub rakes are compact rakes designed for raking in tight spaces such as in and around shrubbery.

Poly head leaf rakes with a fan shape edge are designed for a sweeping motion to remove leaves, grass, and other loose debris from lawn surfaces.

Lawn rakes feature steel spring braces to enable the tines to penetrate grass to remove thatch and other debris. The straight edge permits raking close to walls, fences, and sidewalks.

Poly-steel head rakes feature poly heads with steel tines and straight edge design to provide performance nearly equal to a steel spring brace rake, but at a lower price.

Photo No.	Model	Quality Level	Description	Head Type	Tines	Head Size	Handle	Grip	UPC	Pack Qty.	Pack Wgt.	Pack Cube
1	LF-8	Good	Shrub rake	Green poly	14	8"	42" wood	—	0 31365 12810 8	12	13.5	3.90
2	LF-20	Better	Leaf rake	Red poly	24	24"	54" wood	—	0 31365 12801 6	12	20.4	3.85
3	LF-20CG	Better	Leaf rake	Red poly	24	24"	54" wood	Cushion	0 31365 12814 6	12	22.0	3.85
4	LF-30P	Better	Leaf rake	Green poly	30	33"	48" wood	—	0 31365 12809 2	12	38.0	4.56
5	LF-30PCG	Better	Leaf rake	Green poly	30	33"	48" wood	Cushion	0 31365 12815 3	12	39.6	4.56
6	PR24	Best	Leaf rake	Black poly	26	24"	51" fiberglass	Cushion	0 36723 00524 4	4	7.3	5.70
7	LF-22PS	Good	Leaf rake	Poly/steel tines	20	22"	48" wood	—	0 31365 12808 5	12	20.0	1.35
8	LF-16	Good	Lawn rake	Steel, spring brace	18	18"	48" wood	—	0 31365 12804 7	12	27.6	2.70
9	LF-22	Good	Lawn rake	Steel, spring brace	22	22"	48" wood	—	0 31365 12807 8	12	22.7	1.70
10	LF-25	Better	Lawn rake	Steel, spring brace	24	24"	54" wood	—	0 31365 12803 0	12	32.2	2.09
11	LF-40	Better	Lawn rake	Steel, spring brace	24	24"	54" fiberglass	Vinyl	0 31365 12800 9	12	31.4	2.09
12	SR22	Best	Lawn rake	Steel, spring brace	24	22"	54" fiberglass	Cushion	0 36723 00522 0	4	13.0	5.50

CUTTING & PRUNING TOOLS

Tree pruners & hedge shears

Adjustable saw blade: Fast cutting adjustable saw blade and non-stick pruning blade for easy use.

Compound-action pruner with 2-pulley cutting system multiplies pruner cutting force.

Extension fiberglass handles telescope for maximum versatility.

Patented STĀ-LOK® positive locking system locks handle securely in place to the exact length needed.

Extension double locking handle of the TP612 provides maximum holding power.



Photo No.	Model	Quality Level	Description	Lopper Type	Lopper Capacity	Saw	F/G Handle Ext. Range	UPC	Pack Qty.	Pack Wgt.	Pack Cube
1	WP-6525	Good	Tree pruner	Compound action	1"	13" blade	6' to 12'	0 31365 05322 6	4	15.0	2.28
2	WP-6535	Good	Tree pruner	Compound action	1-1/8"	13" blade	6' to 12'	0 31365 05334 9	4	17.2	2.28
3	WP-6555	Better	Tree pruner	Compound action	1-1/8"	13" blade	7' to 14'	0 31365 05337 0	4	28.6	3.01
4	TP612	Best	Tree pruner	Compound action	1-1/8"	15" blade	6' to 12'	0 36723 03612 5	4	24.0	2.68
5	SB15	Best	Replacement saw blade for TP612		—	15" blade	—	0 36723 36913 2	12	4.5	0.26



Compound action lever multiplies handle force to cutting blade for easier cutting with less fatigue.

Cutlery steel blades with serrated top blade for fast cutting.

Extension handles featuring the patented STĀ-LOK® positive locking system increases the reach of Struction hedge shears and loppers.

Photo No.	Model	Quality Level	Description	Blades	Handle	Grip	UPC	Pack Qty.	Pack Wgt.	Pack Cube
1	WP-3210	Good	Hedge Shears	8" with pruning notch	9" tubular steel	Vinyl	0 31365 05315 8	6	11.4	0.47
2	WP-3220	Good	Hedge Shears	8" with pruning notch	10" hardwood	—	0 31365 05316 5	6	14.0	0.47
3	WP-3230	Better	Hedge Shears	9" compound action	10" hardwood	Cushion	0 31365 05317 2	6	16.5	0.65
4	EXS24	Best	Hedge Shears	8.75" forged head	Fiberglass, extends from 24" to 36"	Cushion	0 36723 01000 2	4	18.5	1.72

Lopping shears



Compound action lever design on pruning tools multiplies handle force to cutting blades for easier cutting.



Extension handles featuring the patented STÄ-LOK® positive locking system increases the reach of Structron loppers and hedge shears.

Photo No.	Model	Quality Level	Description	Head Type	Cutting Capacity	Handle	Grip	UPC	Pack Qty.	Pack Wgt.	Pack Cube
1	WP-2110	Good	Anvil lopper	Single action	1.5"	19" tubular steel	Vinyl	0 31365 05307 3	6	14.8	0.98
2	WP-2120	Good	Bypass lopper	Single action	1.25"	19" tubular steel	Vinyl	0 31365 05308 0	6	15.0	0.98
3	WP-2130	Better	Bypass lopper	Single action	1.25"	20" hardwood	Cushion	0 31365 05309 7	6	18.0	1.14
4	WP-2135	Better	Anvil lopper	Single action	1.5"	20" hardwood	Cushion	0 31365 05331 8	6	15.7	1.14
5	WP-2136	Better	Bypass lopper	Single action	1.25"	30" hardwood	—	0 31365 05328 8	6	20.5	1.84
6	WP-2137	Better	Bypass lopper	Single action	1.25"	30" hardwood	Cushion	0 31365 05329 5	6	20.5	1.84
7	WP-2140	Best	Bypass lopper	Compound action	2.0"	20" hardwood	Cushion	0 31365 05310 3	6	19.9	2.48
8	WP-2145	Best	Anvil lopper	Compound action	2.0"	20" hardwood	Cushion	0 31365 05333 2	6	23.4	2.48
9	EXB36	Best	Bypass lopper	Single action	1.5"	Fiberglass, extends from 24" to 36"	Cushion	0 36723 01010 1	4	14.5	2.17
10	EXA36	Best	Anvil lopper	Compound action	2.0"	Fiberglass, extends from 24" to 36"	Cushion	0 36723 01020 6	4	24.0	2.17
11	BL24	Best	Bypass lopper	Single action	1.5"	24" fiberglass	Cushion	0 36723 01011 8	4	14.5	1.75
12	CL24	Best	Anvil lopper	Compound action	2.0"	24" fiberglass	Cushion	0 36723 01021 7	4	16.0	1.75

Hand pruners and saws



1
WP-1010



2
WP-1020



Bypass design pruner and lopper blades are designed to cut green, growing, or wet wood.



Anvil design pruner and lopper blades are designed to cut dead, dying, or dry wood.



3
WP-1030



4
WP-8708



5
WP-7621



6
WP-7624



7
WP-7630

Replacement bow saw blades available.

SEYMOUR
THE WORLD'S BEST TOOLS
STRUCTRON

Photo No.	Model	Quality Level	Description	Cutting Capacity	Handle	UPC 0 31365 +	Pack Qty.	Pack Wgt.	Pack Cube
1	WP-1010	Good	Bypass hand pruner	1/2"	Comfort molded, quick release	05300 4	12	4.1	0.20
2	WP-1020	Better	Anvil hand pruner	Compound action, 5/8"	Textured vinyl grips, enclosed spring	05301 1	12	8.5	0.30
3	WP-1030	Better	Bypass hand pruner	Compound action, 5/8"	Textured vinyl grips, enclosed spring	05302 8	12	9.0	0.30
4	WP-8708	Best	Folding pruning saw	8" steel blade	Comfort poly grip with safety lock	05330 1	12	8.2	0.49
5	WP-7621	Best	Bow saw	21" steel blade with guard	Tubular steel	05325 7	12	15.0	0.75
6	WP-7624	Best	Bow saw	24" steel blade with guard	Tubular steel	05326 4	12	18.0	1.17
7	WP-7630	Best	Bow saw	30" steel blade with guard	Tubular steel	05327 1	12	20.0	1.48

Weed and brush cutting tools





SEYMOUR
The World's Best Tools!

FOR HEAVY DUTY BRUSH CUTTING

- Hardened, machine steel blade
- Top grain hardwood handle
- Overall length 32 inches
- Made in USA

DITCH BANK BLADE

Attractive packaging for the ditch bank blade provides effective pegboard and slatwall merchandising and customer protection.



The WE-20 double edge weeder is perfectly balanced for fast, efficient cutting.

The WE-40 heavy-duty blade may be sharpened and is replaceable.

SEYMOUR
THE WORLD'S BEST TOOLS!
STRUCTRON

Photo No.	Model	Description	Head size	Ferrule	Handle	UPC 0 31365 +	Pack Qty.	Pack Wgt.	Pack Cube
1	WE-20	Weed cutter, serrated edges, formed steel brackets	14" x 2.5"	—	30" hardwood	05120 8	6	17.6	3.12
2	WE-30	Grass whip, serrated blade riveted to steel shaft	11" x 1.5"	Steel	12" hardwood	05140 6	6	7.5	0.79
3	WE-40	Brush cutter, heavy-duty, replaceable steel blade	12" x 4"	—	30" hardwood	05150 5	3	10.7	2.24
6	DT-1640	Ditch bank blade, steel blade bolted to formed steel brackets	16" x 7.5"	—	40" hardwood	05090 4	6	33.0	1.10
7	WE-35	Dandelion/lawn weeder, steel tip	2.5" x 1"	Steel	36" hardwood	05035 5	6	8.0	0.29

Grass hooks and turf edgers



1
2G-497



2
2G-25



4
2G-25LH



3
2G-507



5
WE-51



6
WE-52



7
SD-20



8
WE-60



9
WE-65



SEYMOUR
THE WORLD'S GREAT TOOLS
STRUCTRON

Vinyl bags for grass hooks provides attractive pegboard and slatwall merchandising and customer protection.

Rotary turf edgers feature self-sharpening 6" zinc plated blades mounted to ribbed rubber tires for superior cutting power.

Half moon turf edgers feature turned steps for comfort and control.

Photo No.	Model	Quality Level	Description	Head size W x H	Handle	UPC 0-31365 +	Pack Qty.	Pack Wgt.	Pack Cube
1	2G-497	Good	Grass hook, general purpose, non-offset serrated edge blade	—	Hardwood	10080 7	6	3.9	0.52
2	2G-25	Better	Grass hook, American pattern, steel ferrule	—	Hardwood	10050 0	6	5.7	0.52
3	2G-507	Better	Grass hook, general purpose, offset plain edge blade	—	Painted hardwood	10090 6	6	3.7	0.52
4	2G-25LH	Better	Long handle grass hook, American pattern, steel ferrule	—	Hardwood	10060 9	6	12.0	1.22
5	WE-51	Better	Rotary turf edger, single wheel, self-sharpening 6" blade	6"	48" hardwood	02400 4	2	4.9	0.68
6	WE-52	Best	Rotary turf edger, double wheel, self-sharpening 6" blade	6"	48" hardwood	02410 3	2	7.9	1.25
7	SD-20	Better	Sod lifter with chrome steel D-grip	8.75" x 5"	30" hardwood	12206 9	3	15.0	1.79
8	WE-60	Good	Half moon turf edger, steel blade welded to steel ferrule	8.75" x 4.5"	48" hardwood	02420 2	2	4.4	0.67
9	WE-65	Better	Half moon turf edger, 12 gauge steel blade, cast-iron socket	8.75" x 4.5"	48" hardwood	02430 1	2	6.0	1.01

SPECIALTY AGRICULTURE

Snaths and scythe blades



SEYMOUR
THE WORLD'S BEST TOOLS!
STRUCTRON



Photo No.	Model	Description	Size (Inches)	Material	UPC 0 31365 +	Pack Qty.	Pack Wgt.	Pack Cube
1	SN-8	Snath, steel web, iron loop bolt, for light-duty cutting	1.25" diam.	Aluminum	04030 1	3	6.8	3.36
2	SN-9	Snath, iron loop bolt, for medium duty cutting	1.5" diam.	Aluminum	04040 0	3	8.9	3.82
3	SN-1	Snath, steel web, iron loop bolt, for grass, weeds, and light brush		Hardwood	04010 3	3	13.8	3.82
4	2B-42B20	Bush scythe	20"	Cutlery steel	10130 9	3	5.9	0.17
5	2B-42W24	Weed scythe	24"	Cutlery steel	10150 7	3	6.2	0.24
5	2B-42W26	Weed scythe	26"	Cutlery steel	01016 8	3	6.9	0.24
6	2B-42G28	Grass scythe	28"	Cutlery steel	10180 4	3	5.6	0.24
6	2B-42G30	Grass scythe	30"	Cutlery steel	10190 3	3	6.2	0.24
7	2B-040128	Scythe, TOPS label, lightweight	28"	Cutlery steel	10240 5	3	4.5	0.43
7	2B-040130	Scythe, TOPS label, lightweight	30"	Cutlery steel	10250 4	3	4.8	0.43
8	SP-16UB	Lower and upper nib for SN-1 and SN-9	1.5" diam.	—	04100 1	6	1.7	0.10
	SP-16LB	Lower bush nib for SN-1	1.75" diam.	—	04102 5	6	1.7	0.10
	SP-16UG	Upper grass nib for SN-1 and both nibs for SN-8	1.25" diam.	—	04101 8	6	1.6	0.10

Machetes, sheaths, and knives

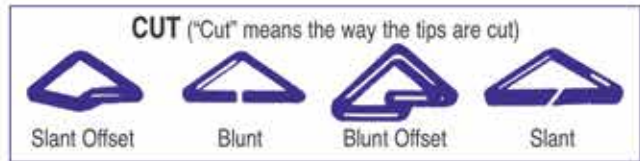

Photo No.	Model	Description	Blade Size	Material	UPC 0 31365 +	Pack Qty.	Pack Wgt.	Pack Cube
1	2P-MA12	Machete, black poly handle, brass rivets	12"	Cutlery Steel	05030 0	12	7.2	0.25
2	2P-MA18	Machete, black poly handle, brass rivets	18"	Cutlery Steel	05040 9	12	11.6	0.34
3	2P-MA22	Machete, black poly handle, brass rivets	22"	Cutlery Steel	05050 8	12	14.1	0.41
4	2P-MA24	Machete, black poly handle, brass rivets	24"	Cutlery Steel	05060 7	12	15.2	0.42
5	2P-MA18S	Sheath for 18" machete, belt loop	for 18"	Canvas	05080 5	12	1.5	0.25
6	2P-MA22S	Sheath for 22" machete, belt loop	for 22"	Canvas	05081 2	12	1.7	0.25
7	2P-MA24S	Sheath for 24" machete, belt loop	for 24"	Canvas	05082 9	12	1.7	0.25
8	2P-CN13	Cane knife, hardwood handle	13"	Cutlery Steel	05020 1	12	13.8	0.35
9	2C-33	Corn knife, flexible steel blade, hardwood handle	1.38" x 18"	Cutlery Steel	10010 4	6	5.4	0.20
10	2C-66	Corn knife, blade tapers to 2.25" at the hardwood handle	15" x 2.75"	Cutlery Steel	10020 3	6	6.4	0.20
11	2C-99	Corn knife, blade tapers to 2.25" at the hardwood handle	18" x 3"	Cutlery Steel	10030 2	6	7.8	0.20

Packaged ring fasteners



MADE IN THE USA



Hog rings are used to prevent swine from rooting in the ground. They are made from copper coated wire and come in various sizes.

Ring fasteners are used for fastening wire fences, slit fences, steel mesh for wall reinforcement, fish traps, crab pots, animal cages, upholstery, and attaching tags. They are also used to clamp rubber tie-down straps and for clamping rope. Seymour rings have a variety of uses in arts and crafts such as fastening holiday wreath materials.

Tab-top boxes: Packaged rings come in convenient tab-top boxes that make them ideal for effective pegboard merchandising. Each box holds from 25 to 100 rings depending on the size of the rings.

10-pack dispenser box: Packaged ring boxes are packed in convenient dispenser cartons with 10 tab-top boxes in each dispenser carton.

BULK RINGS

Bulk rings prices are listed in the price list and special order rings are available on a quotation basis. For special needs, just provide samples or specifications.

Rings are defined by wire gage or diameter, material properties and cost, pattern, and cut. The ring wire materials below are listed in order of relative cost, with the least expensive listed first. For best value, select the lowest cost material that has the properties needed for the intended application.

Bright basic steel rings are the most economical and are used for general purpose applications such as attaching tags.

Copper coated rings are economical and used for hog rings and general purpose applications.

Galvanized steel rings are best for applications such as fencing where moderate cost and resistance to rust are important.

Aluminum rings are relatively expensive, light weight and won't rust or corrode making them ideal for salt water use, cages and traps, and other special requirement applications.

Stainless steel rings are the most expensive and won't rust or corrode making them ideal for salt water use, cages and traps, food industry applications, and other special requirement applications.

Hill pattern rings close in a triangle shape.

Blair pattern rings close in an oval shape.

Prebent rings reduce the effort needed to close the rings thus reducing hand fatigue.

Rope tie pattern rings are ideal for clamping rope and cable.

Upholstery pattern rings are designed to hold fabric to furniture frames.

Slant cut rings are best for applications requiring penetration such as upholstery and hog rings.

Blunt cut rings are best for applications such as fencing. They have no sharp points to cut or pierce, making them safer to handle.

Non-offset rings close with the tips nearly touching. They are ideal for fastening large diameter materials such as fence wire where a small gap between the tips is OK.

Offset ring design allows the ring tips to pass for complete closure. They are best for fastening small diameter materials that could pass through a small gap.

Photo No.	Model	Description	Point Style	Wire Gage	Material	Pieces Per Box	UPC 0 31365 +	Pack Qty.	Pack Wgt.	Pack Cube
1	RN-H1	Hill pig rings	Slant	12.5	Copper plated steel	100	06010 1	10	4.1	0.07
	RN-H2	Hill shoat rings	Slant	12.5	Copper plated steel	100	06020 0	10	4.6	0.07
	RN-H3	Hill hog rings	Slant	12.5	Copper plated steel	100	06030 9	10	5.3	0.09
	RN-H4	Hill hog rings	Slant	11.0	Copper plated steel	65	06040 8	10	6.0	0.09
	RN-B1	Blair pig rings	Slant	12.5	Copper plated steel	100	06050 7	10	4.6	0.07
	RN-B2	Blair shoat rings	Slant	12.5	Copper plated steel	100	06060 6	10	5.1	0.07
	RN-B3	Blair hog rings	Slant	12.5	Copper plated steel	100	06070 5	10	5.8	0.09
	RN-PBH1	Hill prebent pig rings	Slant	12.5	Copper plated steel	100	06080 4	10	4.3	0.09
	RN-PBH2	Hill prebent shoat rings	Slant	12.5	Copper plated steel	100	06090 3	10	5.2	0.09
	RN-PBH3	Hill prebent hog rings	Slant	12.5	Copper plated steel	100	06100 9	10	5.5	0.09
2	RN-X1	Humane pig rings	Slant	11.0	Copper plated steel	25	06140 5	10	3.2	0.07
	RN-X3	Humane hog rings	Slant	11.0	Copper plated steel	25	06150 4	10	3.9	0.09
	RN-541	Cage/trap rings	Blunt	14.0	Stainless steel	5 lbs	06790 2	8	41.0	0.28
	RN-542	Cage/trap rings	Slant	14.0	Stainless steel	5 lbs	06795 7	8	41.0	0.28
	RN-641	Cage/trap rings	Blunt	14.0	Galvanized steel	5 lbs	06800 8	8	41.0	0.28
	RN-642	Cage/trap rings	Slant	14.0	Galvanized steel	5 lbs	06810 7	8	41.0	0.28
	RN-741	Cage/trap rings	Blunt	11.0	Aluminum	2 lbs	06820 6	8	16.4	0.28
	RN-742	Cage/trap rings	Slant	11.0	Aluminum	2 lbs	06830 5	8	16.4	0.28

Bulk ring fasteners, ringer pliers



Ringer pliers are specially designed to hold and close hog rings and ring fasteners. The chart below indicates which pliers to use with the various ring patterns.

RR-SM Small
541, 542, 641, 642, 741, 742, all rings less than 3/4"

RR-HM Hill
H1, H2, H3, PBH1, PBH2, PBH3, B1, B2, B3

RR-HS Hill spring
H1, H2, H3, PBH1, PBH2, PBH3, B1, B2, B3

RR-HLM Hill wide jaw
H4, all heavy wire rings

RR-HHM Hill heavy
H4, all heavy wire rings

RR-SHB Stewart
H1, H2, H3, PBH1, PBH2, PBH3, B1, B2, B3

RR-XM Humane
X1, X3, H1, H2, H3, PBH1, PBH2, PBH3, B1, B2, B3

RR-DN De Neui
H1, H2, PBH1, PBH2, B1, B2

Photo No.	Model	Description	Point Style	Wire Gage	Material	Pieces per Cwt.
1	RN-1H1	Hill pig rings, bulk pack	Slant	12.5	Copper plated steel	28,000
	RN-1H2	Hill shoat rings, bulk pack	Slant	12.5	Copper plated steel	23,600
	RN-1H3	Hill hog rings, bulk pack	Slant	12.5	Copper plated steel	20,600
	RN-1H4	Hill hog rings, bulk pack	Slant	11.0	Copper plated steel	10,800
2	RN-1B1	Blair pig rings, bulk pack	Slant	12.5	Copper plated steel	24,000
	RN-1B2	Blair shoat rings, bulk pack	Slant	12.5	Copper plated steel	20,500
	RN-1B3	Blair hog rings, bulk pack	Slant	12.5	Copper plated steel	18,800
3	RN-1PBH1	Hill prebent pig rings, bulk pack	Slant	12.5	Copper plated steel	26,000
	RN-1PBH2	Hill prebent shoat rings, bulk pack	Slant	12.5	Copper plated steel	22,600
	RN-1PBH3	Hill prebent hog rings, bulk pack	Slant	12.5	Copper plated steel	18,200

The standard pack for bulk rings is 50 pounds. They can also be packed in 1 pound, 5 pound, 10 pound, and 25 pound boxes. Prices are based on minimum shipments of 100 pounds.

Photo No.	Model	Description	Material	UPC 0 31365 +	Pack Qty.	Pack Wgt.	Pack Cube
5	RR-HM	Hill ringer pliers	Malleable iron casting with chrome finish	07010 0	10	5.0	0.10
6	RR-HS	Hill spring ringer pliers	Malleable iron casting with chrome finish	07020 9	10	4.6	0.10
7	RR-HLM	Hill wide jaw ringer pliers	Malleable iron casting with chrome finish	07030 8	1	0.6	0.02
8	RR-HHM	Hill large ringer pliers	Malleable iron casting with chrome finish	07040 7	1	0.8	0.02
9	RR-SHB	Stewart ringer pliers	Malleable iron casting with chrome finish	07050 6	10	6.2	0.10
10	RR-XM	Humane ringer pliers	Malleable iron casting with chrome finish	07060 5	10	9.2	0.10
12	RR-SM	Small ringer pliers	Malleable iron casting with chrome finish	07090 2	1	0.4	0.01
13	RR-DN	Denui ringer pliers	Malleable iron casting with chrome finish	07100 8	10	4.8	0.10
14	RB-31	Bull ring, 5/16" x 2-1/2", solid brass, hinged and secured with solid brass set screw		03100 2	1	0.2	0.01
15	RB-53	Bull ring 3/8" x 3", solid brass, hinged and secured with solid brass set screw		03110 1	1	0.4	0.01

FIRE STARTER

Fire pits, campfires, charcoal, and fireplace



30-052



30-050



30-054

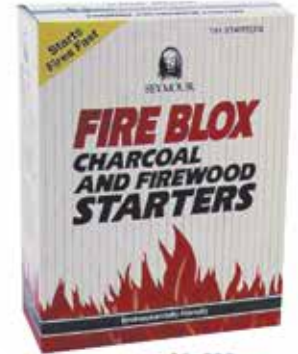

30-589



Here's why your customers will prefer Seymour FIRE BLOX™ over all other fire starters.

Fire Blox are superior to liquids and other solid starters.

Seymour Fire Blox have many advantages your customers will want. These benefits will bring them back - the repeat business you want and need.

Starts all types of fires

- Great for starting firewood, pellets, coal and charcoal.
- Works in both catalytic and non-catalytic stoves.
- Eliminates the need for liquids, kindling and newspapers.

Works great even after being submerged in water.

- Pieces burn hot for about 12 minutes for fast, sure starts.
- Lights quickly, even when wet.
- Will ignite even damp firewood.

Safe to use anywhere

- Can't leak, spill, flash, flare-up or explode.
- Eliminates dangerous second squirts of flammable liquids.
- Safe to use both indoors and outdoors.
- Non-poisonous.
- Stores safely anywhere and keeps indefinitely.

Economical - just pennies per light.

- Need only two or three pieces per start.
- A 24-piece package provides 8 to 12 starts, more than most starters.
- Pieces are scored and will separate easily so that just the right amount may be used.

Burns clean

- Meets the strictest air quality codes in the country.
- Certified as clean burning and approved for sale in California including the Los Angeles Area of Southern California.

Fire Blox packages

Packaged five ways to conveniently serve your customers.

30-050 Fire Blox carton, 24 starters.

30-052 Fire Blox, cello-pack, 24 starters.

30-054 Fire Blox trial size cello-pack, 4 starters.

30-589 Fire Blox bulk carton, 144 starters.

30-580 Seymour Safe Start carton, 36 starters.

Fire Blox 12-pack shipper

Shipper with 12 cartons or cello-packs.

30-050-12 carton shipper.

30-052-12 cello-pack shipper.



30-580

Fire starter - Fire pits, campfires, charcoal, and fireplace



SEYMOUR

Fire Blox 24-pack shipper/display

The 24-pack shipper cartons for the 30-050 and 30-052 Fire Blox can be quickly converted to an attention-getting full-color shelf display with header card.

30-050-24 Carton shipper/display.

30-052-24 Cello-pack shipper/display.

Trial size shipper

Shippers with 104 trial size cello-packs.

30-054-104 Trial size shipper/display.

30-054-104PB Trial size plain box shipper.

Fire Blox 72-pack floor displays

Generate profits with a sales boosting floor display. Comes prepacked with 72 cartons or cello-packs.

30-050-72 Floor display with cartons.

30-052-72 Floor display with cello-packs.

MADE IN THE USA



30-050-24

30-050-72

SEYMOUR CLASSIC COLLECTION

Handcrafted hardwood handle firesets

30-203 Early American fireset. Four-piece set. Hardwood handles and center post. H 29.25". Made in U.S.A.

30-223 Colonial fireset. Five-piece set with hardwood handles attached to strong 3/8" steel shafts. Hardwood center posts mounted on sturdy steel base. Steel tool holder with brass finial. Tools include shovel, brush, harpoon firetender, and tongs. H 29". Made in U.S.A.

30-255 Homestead fireset. Four-piece, heavy duty set with contoured hardwood handles and brass ferrules attached to heavy gauge steel shafts. The base and tool holder are heavy cast iron. Tools include shovel, brush and fork firetender. H 33". Made in U.S.A.

30-230 Classic fireset. Four-piece set with classical styled hardwood handles with leather thongs. Tools are 30" long. Solid brass ferrules, wrought iron tripod stand. Tools include shovel, brush and firetender. H 32". Made in U.S.A.

30-216 Wood handle mini fireset. Ideal for wood stoves and fireplace inserts. Four-piece set with hardwood handles. Tools include shovel, brush and ash rake. H 18". Made in U.S.A.

Handcrafted quality bellows

30-671 Cast eagle bellows. Walnut finished, hardwood sides, cast eagle medallion and brass plated nozzle. Size 6" x 15".



SEYMOUR CLASSIC COLLECTION

Deluxe, heavy duty five-piece firesets

30-2650031 Polished brass fireset.
Five-piece, ball handles, lever action tongs. H 33".

30-2650032 Antique brass fireset.
Five-piece, ball handles, lever action tongs. H 33".

30-2650033 Black fireset.
Five-piece, ball handles, lever action tongs. H 33".

30-2650034 Black and polished brass fireset.
Five-piece, ball handles, lever action tongs. H 33".

30-2651191 Polished brass fireset.
Five-piece, ball handles, scissor tongs, full gallery base. H 30.5".

30-2651172 Antique brass fireset.
Five-piece, full gallery base, finial handles, scissor tongs. H 30".

30-2652067 Black fireset.
Five-piece, ball handles, rectangular base. H 28.5".



30-2650031
30-2650032



30-2650033



30-2650034



30-2640103

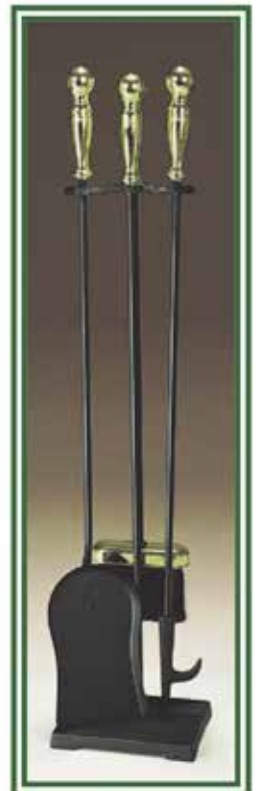

30-2640104

SEYMOUR CLASSIC COLLECTION



30-2651191



30-2651172



30-2652067

Deluxe, four-piece firesets

30-2640103 Black fireset.
Four-piece, ball handles. H 29.5".

30-2640104 Black and polished brass fireset.
Four-piece, rectangular base, brass ball handles and brush cover. H 25.5".

30-2640061 Polished brass fireset.
Four-piece, ball handles, rectangular base. H 29.5".

30-2640062 Antique brass fireset.
Four-piece, ball handles, rectangular base. H 29.5".

30-2640084 Black and polished brass fireset.
Four-piece, ball handles, full gallery base. H 29.5".



30-2640061



30-2640062



30-2640084

SEYMOUR CLASSIC COLLECTION

Fireplace grates

Cast iron one-piece grates

30-2682818 grate. 18" W x 12" D.

30-2682924 grate. 24" W x 15" D.

30-2682927 grate. 27" W x 15" D.



30-2682924

Steel bar one-piece grates

30-45181 grate. 5/8" square bar, shallow depth, 18" FW x 15" BW x 12" D, four bars.

30-45243 grate. 5/8" square bar, 24" FW x 20.5" BW x 15" D, five bars.

30-45273 grate. 5/8" square bar, 27" FW x 23.5" BW x 15" D, six bars.



30-45273

Stack-it Bracket storage assembly fixtures

Stack-It Brackets are steel fixtures used to hold two-by-fours together for storage racks, shelving, workbenches, and stands.

Protects firewood. Stack-It Bracket's unique, patented design keeps firewood high, dry and safe from pests and decay.

Adjustable. Stack-It Bracket racks can be built to any length.

Easy to use. Simple, fast assembly and disassembly without tools, screws or bolts. Patent No. 4,616,757. Made in U.S.A.

30-360 Stack-It Bracket set. Packaged as sets with four brackets per set. Made in U.S.A.

30-360



SEYMOUR CLASSIC COLLECTION

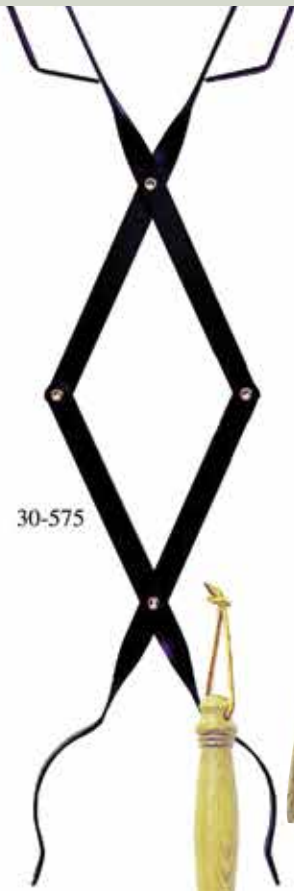

30-575



30-577



30-573



30-574



30-585



30-584



30-586



30-590



30-578



30-560



30-592

SEYMOUR CLASSIC COLLECTION

Individual tools

Individual hardwood handle fireplace tools. All these tools have hardwood handles with leather thongs for hanging. Made in U.S.A.

30-573 Ash rake. L 23".

30-574 Harpoon firetender. Tip imported. L 24".

30-585 Fork firetender. L 24".

30-584 Shovel. L 28".

30-586 Brush. L 24".

Scissor-action tongs

30-575 Black iron scissor tongs. Flat black iron with solid brass rivets. Formed ends clamp logs tightly. L 24". Made in U.S.A.

30-2682113 Black scissor tongs. L 29".

Fireside accessories

30-577 Natural broom. Early American hardwood handle and natural straw. L 26".

30-560 Shorty broom. Hardwood handle and black straw. Compact, convenient size. L 12½".

30-578 Black broom. Early American hardwood handle and black straw. L 26".

30-572 Wood handle sizzle stick. Hardwood handle and solid steel black shaft. L 33".

30-2682185 Corn popper. Black, L 27".

30-590 Black poker. Ball handle, L 27".

30-592 Black shovel. Ball handle, L 27".

30-591 Black broom. Ball handle, L 27".

Replacement brushes

Replacement brush heads are available for all fireplace tool set brushes. Specify tool set model number when ordering.

30-279 Replacement brush. 4 row.



30-572



30-591

SEYMOUR CLASSIC COLLECTION

Seymour fireplace matches



30-059

30-059 Hearth matches, 11".
High quality, fireplace and
stove matches. 90 count.

Hearth rugs

Hard working, good looking rugs add color and comfort. Flame resistant, easy care plush berber carpets are machine washable with skid resistant backs for added safety. Durable Olefin carpets have jute backs for long wear and clean easily with soap and water. Rugs have permanently screened designs and are made and printed in the U.S.A. For fireplaces, stoves, entryways, bedrooms and bathrooms.



30-340

30-340 Steel rug display fixture.

Display holds 24 rugs, and includes 24 hangers and sign.

Hearth rugs



30-838 Garden walk,
23-1/2" x 40" Berber



30-846 Soft Sand,
23-1/2" x 40" Berber



30-837 Chickadee Border,
23-1/2" x 40" Berber

SEYMOUR CLASSIC COLLECTION



Log racks

30-2682413 Four-foot log rack. Half face cord, black, 48" x 48", heavy duty tubular steel.

30-2682433 Eight-foot log rack. Full face cord, black, 96" x 48" heavy duty tubular steel.

30-2682519 Four-foot log rack cover. For 48" x 48" log rack, heavy-duty rip-stop woven fabric, Velcro tabs to close flap, water repellent, mildew resistant.

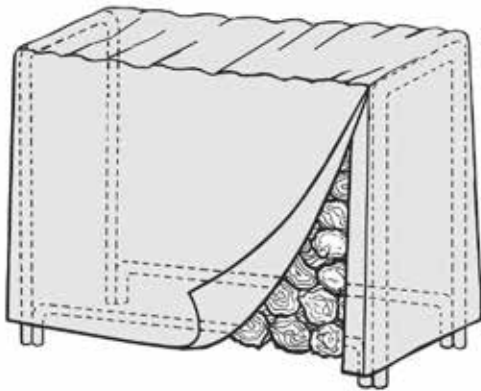

Log rack cover

30-2682529 Eight-foot log rack cover. For 96" x 48" log rack, heavy-duty rip-stop woven fabric, Velcro tabs to close flap, water repellent, mildew resistant.

Log baskets

30-2681541 Log basket. Polished brass. L 21".

30-2681542 Log basket. Antique brass. L 21".

30-2681543 Log basket. Black. L 19".

30-2681554 Log basket. Black and brass. L 21".



SEYMOUR CLASSIC COLLECTION

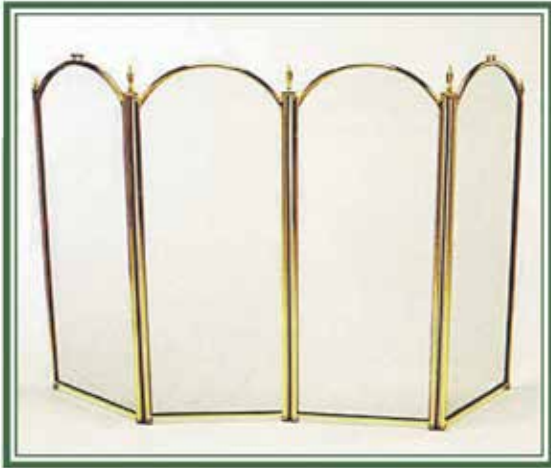

30-2670081, 30-2670082

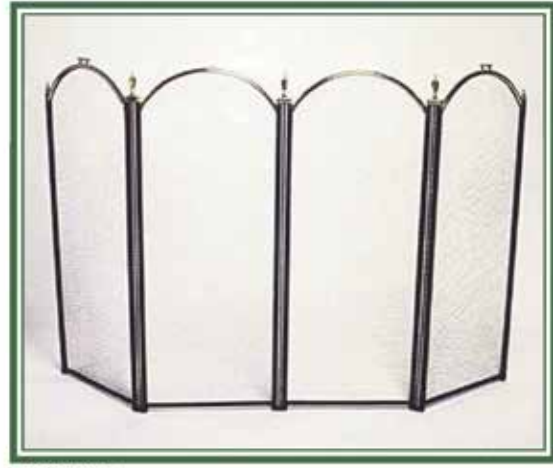

30-2670083



30-2670133

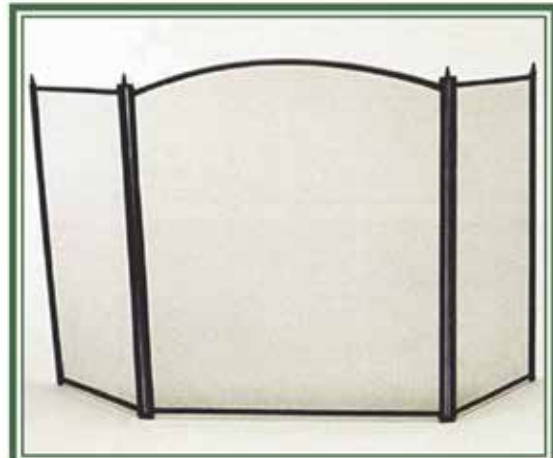

30-2670203

Folding firescreens

30-2670081 Polished brass, four-panel firescreen.
Tubular frame, arch top, wire screen. H 33", W 51".

30-2670082 Antique brass four-panel firescreen.
Same as above except finish.

30-2670083 Black and polished brass four-panel firescreen.
Same as above except finish.

30-2670133 Black four-panel firescreen.
Steel rod frame, wire screen. H 28.5", W 52".

30-2670203 Black three-panel firescreen.
Tubular frame, wire screen, oval top front.
H 31", W 52".

30-2697044 Black and polished brass three-panel firescreen.
Polished brass top rail and accents,
wire screen. H 30.5", W 52".



30-2697044

SEYMOUR CLASSIC COLLECTION



Log carriers

30-376 Leather log carrier. Heavy natural top-grain pig skin with reinforced leather handles. L 33", H 15".

30-2682383 Tan canvas log carrier. Heavy duty, cotton canvas with sewn "box" ends to capture dirt and bark. Tan with various color trim. L 32", H 18".



Fireside accessories

30-990 Color cone basket. A tissue-lined basket containing approximately 60 pine cones that have been chemically treated to produce dancing blues and greens that enhance any fireplace or glass door stove. (Not for use on gas logs.) Made in U.S.A.

30-992 Potpourri. A hand picked mixture of lightly scented pine cones that will add a pleasing aroma and beauty to any fireside. Made in U.S.A.

30-991 Color cone box. Attractive box with over 30 pine cones chemically treated to give off an array of blues and greens when added to a fire. (Not for use on gas logs.) Made in U.S.A.

30-525 Color flame crystals. Just sprinkle these crystals on a fire for an array of dancing colors. (Not for use on gas logs.) Made in U.S.A.



30-525



30-990



30-992



30-991

SEYMOUR CLASSIC COLLECTION



Fireside accessories

30-2682624 Kettle. Black cast iron steamer kettle with brass handle. Three quart. (Not for cooking for human consumption.)

30-2682403 Hearth safety gloves. Brown leather, cotton lined, 14" pair, poly bag with header card.

30-301 Black coal hod. Heavy gauge steel painted with black semi-gloss enamel with heavy gauge black wire bale.

30-303 Ash shovel. Heavy gauge steel with black baked enamel finish.

30-305 Ash bucket/shovel. Ash or charcoal container and shovel set. Durable steel construction, double thick bottom. High heat, corrosion resistant. Heavy gauge steel painted with semi-gloss enamel. Has brass bale with turned wooden handle. Six gallon capacity. Holds 20 lbs of charcoal.



SEYMOUR CLASSIC COLLECTION

Merchandise display

30-140 Display fixture only. A proven successful point-of-sale display for tools and accessories. This all-steel fixture comes complete with hooks for the display of items in the 30-141 merchandise assortment. H 53", W 24", D 9". Made in U.S.A.

30-141 Merchandise assortment. A collection of best-selling Seymour items. Perfect assortment for impulse sales.

Assortment contains:

- 24 ea. 30-059 Hearth matches.
- 72 ea. 30-050 Fire Blox cartons.
- 24 ea. 30-525 Color Flame Crystals.
- 6 ea. 30-2682403 Leather gloves.
- 8 ea. 30-574 Harpoon firetender.
- 8 ea. 30-584 Shovel.
- 8 ea. 30-573 Ash rake.
- 6 ea. 30-578 Black straw broom.



LINK HANDLES

MADE IN THE USA

Tool handles can be made from a variety of hardwoods as well as fiberglass and steel. Each material has certain advantages and disadvantages for replacement handles.

American hickory and ash

The best replacement handles are made from American hickory and American ash because of their strength, elasticity, and ability to absorb shock. Hardwood handles do not conduct electricity.

Shock-absorbing American hickory



American hickory is dense, heavy, and a natural shock absorber making it ideal for striking and cutting tool handles.

The long fibers and unique cell structure of American hickory allow it to flex repeatedly and return to its original shape. It absorbs and dissipates shock before it reaches the user's hands.

The best hickory is grown in the Tennessee region of the USA

The best American hickory logs come from Tennessee, Kentucky, North Carolina, and South Carolina. This region has the ideal combination of soil minerals, rainfall, and sunshine to produce trees that grow slowly and uniformly for exceptional strength.

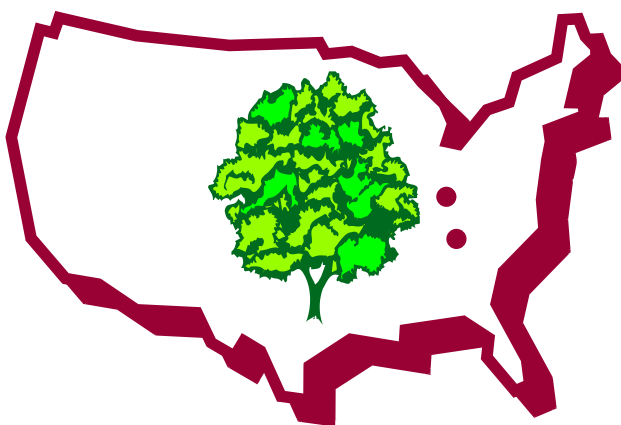

Proudly made in Indiana & Tennessee.

Wood from slower growing trees is denser and thus stronger than the lighter wood that comes from faster growing trees.

All Link hickory comes from the Tennessee region of the USA. Some hickory grows in the northeastern United States, but it is generally of lower quality than the hickory grown in the Tennessee region.

American ash handles for agricultural tools



Most agricultural tool handles such as shovels, rakes, and hoes are made from American ash. It has a uniform grain structure that provides both the strength and the elasticity needed for the bending stresses these tools must endure.

Other hardwoods

When ash or hickory is not used, other hardwoods suitable for the application are used.

For example, a leaf rake does not need a strong and expensive handle when compared to more demanding applications such as axes and shovels.



Fiberglass handles

Fiberglass handles are strong, lightweight, and do not conduct electricity. Fiberglass, however, is not flexible and does not absorb shock. Fiberglass handles cost more than hardwood handles.

Link has a line of eight fiberglass replacement handles.



Steel handles

Steel handles are extremely strong, but they are heavy and expensive. They are not flexible and do not absorb shock. Steel handles conduct electricity.

Link does not make steel replacement handles.

CUSTOMER SERVICE 800-457-1909

Turned handles are ergonomically superior to shaped handles

There are two ways to produce handles: shaping and turning.

Shaped handles are made from flat boards that are smoothed and rounded on the top and bottom. Shaping is a faster and less costly way to make handles. They can provide good value for occasional use applications.

Turned handles are made on a lathe from wood blanks that are about 25% larger than the flat boards. The result is a handle that has better grips and contours.

Anyone who holds a shaped handle and then a turned handle will immediately feel the higher quality of the turned handle.

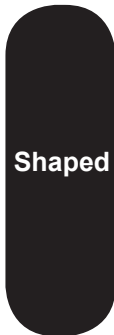

Shaped



Turned

Superior ergonomic design

Link handles are designed with the best combination of length and contours so the user can best hold the handle and use the tool.

The handle shape works with the users, and the handle becomes an extension of their bodies to provide better comfort, control, and safety.



The best quality replacement handles are turned rather than shaped. Turning handles from wood squares results in ergonomically superior handles that provide better comfort, control, and safety.

STEPS IN MAKING A TURNED AXE HANDLE



1. Start with an axe wood square or blank.



2. Half turned axe handle.



3. Full rough turned axe handle.



4. Axe handle after sanding.



5. Finished axe handle with label and wedge.

All handles are carefully graded and sorted

Link’s experienced timber buyers grade log quality. They are looking for logs that are heavy and defect-free.

When the logs are sawed into squares (or blanks), the squares are graded. After the squares are turned into handles, they are graded again.

Primary log quality factors

Some of the factors used to determine quality include:

- Straightness of grain
- Moisture content
- Density
- Freedom from defects

Wood color not a quality factor

Color of the wood is not a factor in determining the quality of hickory handles. The best hickory handles may be all white, red-and-white, or all red.

Link American hickory quality levels

01 Best quality American hickory with sanded finish and yellow non slip grip. Meets or exceeds all government “A” specifications. Ideal for the most demanding industrial and commercial applications.

02 Best quality American hickory with a wax finish. Meets or exceeds all government “A” specifications. Ideal for the most demanding industrial and commercial applications.

04 Better quality American hickory with a wax finish. Ideal for frequent heavy-duty use by farmers, ranchers, contractors and other professionals with demanding construction and other professional applications.

19 Better quality American hickory with a clear lacquer finish. Fire finish provides a highly pleasing appearance. Ideal for frequent heavy-duty use by farmers, ranchers, contractors and other professionals with demanding construction and other professional applications.

08 Good quality American hickory with wax finish. These handles provide exceptional value and economy for homeowner and other occasional use applications.

Link American ash quality levels

18 Best quality American ash with a clear lacquer finish. Ideal for the most demanding industrial and commercial applications.

21 Better quality American ash with a clear finish. Ideal for frequent heavy-duty use by farmers, ranchers, contractors and other professionals with demanding construction and other professional applications.

SUMMARY OF LINK QUALITY LEVELS

Quality level #	Quality level	Type of finish	Special features	Govt. specs	Suggested use
AMERICAN HICKORY					
01	Best	Sanded	Non-slip grip	A	Industrial, commercial
02	Best	Wax		A	Industrial, commercial
04	Better	Wax			Contractor, professional
19	Better	Clear lacquer	Fire finish		Contractor, homeowner
08	Good	Wax			Homeowner
AMERICAN ASH					
18	Best	Clear lacquer			Industrial, commercial
21	Better	Clear lacquer			Contractor, homeowner

AXE AND BUSH HOOK HANDLES

Single bit curved grip axe handles

For 3 to 5 lb. axes and bush hooks, eye 2-5/16" x 3/4"



Model	Length	UPC 0 25545 +	Pack qty	Pack wgt	Pack cube
100-01	36"	10001-5	12	18.0	0.92
100-02	36"	10002-2	12	18.0	0.92
100-04	36"	10004-6	12	18.0	0.92
100-08	36"	10008-4	12	18.0	0.92
100-19	36"	10019-0	12	18.0	0.92
102-02	32"	10202-6	12	15.0	0.92
102-08	32"	10208-8	12	15.0	0.92
102-19	32"	10219-4	12	15.0	0.92
104-08	28"	10204-2	12	12.0	0.92

Boys single bit curved grip axe handles

For 2-1/4 lb. axes, eye 2-1/16" x 11/16"



Model	Length	UPC 0 25545 +	Pack qty	Pack wgt	Pack cube
116-02	28"	11602-3	12	10.0	0.66
116-08	28"	11608-5	12	10.0	0.66
116-19	28"	11619-1	12	10.0	0.66

House curved grip axe handles

For 2-1/4 lb. axes, eye 2-1/16" x 11/16"



Model	Length	UPC 0 25545 +	Pack qty	Pack wgt	Pack cube
118-04	18"	11804-1	12	8.0	0.60
118-19	18"	11819-5	12	8.0	0.60

Straight single bit axe handles

For 3 to 5 lb. axes, eye 2-1/2" x 13/16"



Model	Length	UPC 0 25545 +	Pack qty	Pack wgt	Pack cube
119-19	36"	11919-2	12	18.0	0.92

Miner's straight single bit axe handles

For 3 to 5 lb. axes, eye 2-1/2" x 13/16"



Model	Length	UPC 0 25545 +	Pack qty	Pack wgt	Pack cube
124-02	27"	12402-8	12	12.0	0.60
124-19	27"	12419-6	12	12.0	0.60

Double bit axe handles

For 3 to 5 lb. axes, some Pulaski axes, and #2 and #3 coal picks, eye 2-7/8" x 5/8"



Model	Length	UPC 0 25545 +	Pack qty	Pack wgt	Pack cube
140-02	36"	14002-8	12	18.0	0.92
140-04	36"	14004-2	12	18.0	0.92
140-08	36"	14008-0	12	18.0	0.92
140-19	36"	14019-6	12	18.0	0.92
142-19	32"	14219-0	12	15.0	0.92

Cruiser's or cedar double bit axe handles

For 2-1/2 lb. axes, eye 2-1/4" x 5/8"



Model	Length	UPC 0 25545 +	Pack qty	Pack wgt	Pack cube
145-02	28"	14502-3	12	10.0	0.66
145-08	28"	14508-5	12	10.0	0.66
145-19	28"	14519-1	12	10.0	0.66

PICK, MATTOCK & GRUB HOE HANDLES

Double bit garden mattock handles

For 2-1/2 lb. mattocks, No. 10 eye 3" x 1"



Model	Length	UPC 0 25545 +	Pack qty	Pack wgt	Pack cube
200-19	36"	20019-7	12	18.0	0.92

Curved grub hoe handles

For 3-1/2 to 5 lb. grub hoes, No. 8 eye 3" x 2"



Model	Length	UPC 0 25545 +	Pack qty	Pack wgt	Pack cube
210-19	36"	21019-6	12	30.0	1.37

Straight grub hoe handles

For 3-1/2 to 5 lb. grub hoes, No. 8 eye 3" x 2"



Model	Length	UPC 0 25545 +	Pack qty	Pack wgt	Pack cube
214-19	36"	21419-4	12	30.0	1.37
215-19	40"	21519-1	12	34.0	1.57

AMERICAN HICKORY
Shock-absorbing
Strong Resilient

PICK, MATTOCK & GRUB HOE HANDLES (cont.)

Small eye grub hoe handles

For 3 lb. grub hoes, No. 9 eye 2-1/2" x 1-7/8" & No. 9 eye 2-1/4" x 1-5/8"



Model	Length	UPC 0 25545 +	Pack qty	Pack wgt	Pack cube
213-19	40"	21319-7	12	32.0	1.66
216-19	40"	21619-8	12	32.0	1.57

Railroad or clay pick or mattock handles

For 5 lb. and heavier picks and mattocks, No. 6 eye 3" x 2"



Model	Length	UPC 0 25545 +	Pack qty	Pack wgt	Pack cube
220-01	36"	22001-0	12	30.0	1.37
220-02	36"	22002-7	12	30.0	1.37
220-04	36"	22004-1	12	30.0	1.37
220-08	36"	22008-9	12	30.0	1.37
220-19	36"	22019-5	12	30.0	1.37

Garden or nursery mattock handles

For 3 lb. mattocks, No. 7 eye 2-3/4" x 1-3/4"



Model	Length	UPC 0 25545 +	Pack qty	Pack wgt	Pack cube
240-04	36"	24004-9	12	25.0	0.92
240-08	36"	24008-7	12	25.0	0.92
240-19	36"	24019-3	12	25.0	0.92

Mattock handle

For Laurel, Dig-Ezy, Southern Queen pattern mattocks, 1-1/2" round eye



Model	Length	UPC 0 25545 +	Pack qty	Pack wgt	Pack cube
813-21	54"	81321-2	6	9.0	0.61

STRIKING TOOL HANDLES

Sledge or maul handles

Oval eye 1-1/4" x 1"



Model	Length	UPC 0 25545 +	Pack qty	Pack wgt	Pack cube
-------	--------	------------------	-------------	-------------	--------------

For 6 to 16 lb. sledge or striking hammers

001-01	36"	00101-5	12	18.0	0.74
001-02	36"	00102-2	12	18.0	0.74
001-04	36"	00104-6	12	18.0	0.74
001-08	36"	00108-4	12	18.0	0.74

001-19	36"	00119-0	12	18.0	0.74
002-01	32"	00201-2	12	16.0	0.60
002-02	32"	00202-9	12	16.0	0.60
002-08	32"	00208-1	12	16.0	0.60
002-19	32"	00219-7	12	16.0	0.60

For 6 to 8 lb. sledge or striking hammers

003-02	30"	00302-6	12	14.0	0.66
003-04	30"	00304-0	12	14.0	0.66
003-08	30"	00308-8	12	14.0	0.66
003-19	30"	00319-4	12	14.0	0.66
004-01	24"	00401-6	12	10.0	0.60
004-08	24"	00408-5	12	10.0	0.60
004-19	24"	00419-1	12	10.0	0.60
009-19	36"	00919-6	12	18.0	0.60

Heavy and extra heavy sledge handles



Model	Length	UPC 0 25545 +	Pack qty	Pack wgt	Pack cube
-------	--------	------------------	-------------	-------------	--------------

For 18 to 24 lb. heavy sledges, eye 1-1/2" x 1-1/4"

010-02	36"	01002-4	12	20.0	0.92
010-19	36"	01019-2	12	20.0	0.92
023-19	32"	02319-2	12	18.0	0.60

Straight double bit eye splitting maul handles

No. 5 eye 2-1/8" x 7/8"



Model	Length	UPC 0 25545 +	Pack qty	Pack wgt	Pack cube
205-02	36"	20502-4	12	18.0	0.92
205-04	36"	20504-8	12	18.0	0.92
205-08	36"	20508-6	12	18.0	0.92
205-19	36"	20519-2	12	18.0	0.92

Straight single bit eye splitting maul & bush hook handles

Eye 2-5/16" x 13/16"



Model	Length	UPC 0 25545 +	Pack qty	Pack wgt	Pack cube
206-02	36"	20602-1	12	18.0	0.92
206-04	36"	20604-6	12	18.0	0.92
206-08	36"	20608-3	12	18.0	0.92
206-19	36"	20619-9	12	18.0	0.92

AMERICAN HICKORY
Shock-absorbing
Strong Resilient

STRIKING TOOL HANDLES (cont.)

Carpenter's adze handles

For house or railroad carpenter's adze, eye 2-5/16" x 1-1/2"



Model	Length	UPC 0 25545 +	Pack qty	Pack wgt	Pack cube
224-02	34"	22402-5	12	20.0	0.92
224-19	34"	22419-3	12	20.0	0.92

Post maul handles



Model	Length	UPC 0 25545 +	Pack qty	Pack wgt	Pack cube
-------	--------	------------------	-------------	-------------	--------------

For cast iron mauls, eye 2" x 1-7/16"

228-01	36"	22801-6	12	20.0	0.92
228-19	36"	22819-1	12	20.0	0.92

For cast iron mauls, eye 2-1/4" x 1-11/16"

229-08	36"	22908-2	12	20.0	0.92
229-19	36"	22919-8	12	20.0	0.92

DITCH BANK BLADE HANDLES

Ditch bank blade handles



Model	Length	UPC 0 25545 +	Pack qty	Pack wgt	Pack cube
-------	--------	------------------	-------------	-------------	--------------

For 4-hole blades

255-19	40"	25519-7	12	22.9	1.02
--------	-----	---------	----	------	------

For 3-hole blades

260-08	40"	26008-5	12	22.8	1.02
260-19	40"	26019-1	12	22.8	1.02
262-19	36"	26219-5	12	21.9	0.92

CLAW HAMMER HANDLES

Claw, ripping, nail hammer handles



Model	Length	UPC 0 25545 +	Pack qty	Pack wgt	Pack cube
-------	--------	------------------	-------------	-------------	--------------

For 16 oz. hammers, eye 1-1/16" x 9/16"

300-02	14"	30002-6	12	5.0	0.20
300-04	14"	30004-0	12	5.0	0.20
300-08	14"	30008-8	12	5.0	0.20
300-19	14"	30019-4	12	5.0	0.20

For 16 oz. and some 20 oz. hammers, eye 1-1/16" x 9/16"

302-02	16"	30202-0	12	6.5	0.21
302-04	16"	30204-4	12	6.5	0.21

For 20, 22, and 24 oz. hammers, eye 1-1/16" x 5/8"

310-02	14"	31002-5	12	5.0	0.18
312-02	16"	31202-9	12	6.5	0.21
312-04	16"	31204-3	12	6.5	0.21
312-08	16"	31208-1	12	6.5	0.21
312-19	16"	31219-7	12	6.5	0.21
313-19	18"	31319-4	12	7.0	0.25

For 28 to 32 oz. hammers, eye 1-3/16" x 3/4"

321-02	16"	32102-1	12	6.5	0.33
321-08	16"	32108-3	12	6.5	0.33
321-19	16"	32119-9	12	6.5	0.33
322-04	18"	32204-2	12	8.0	0.32
322-19	18"	32219-6	12	8.0	0.32

For 13 oz. hammers, eye 1" x 1/2"

325-02	13"	32502-9	12	4.0	0.18
325-04	13"	32504-3	12	4.0	0.18
325-08	13"	32508-1	12	4.0	0.18
325-19	13"	32519-7	12	4.0	0.18

For 7 oz. hammers, eye 7/8" x 1/2"

327-04	12"	32704-7	12	3.0	0.12
327-19	12"	32719-1	12	3.0	0.12

Claw, ripping, nail octagon body hammer handles

For octagon body, 16 oz. hammers, eye 1-1/16" x 9/16"



Model	Length	UPC 0 25545 +	Pack qty	Pack wgt	Pack cube
304-02	14"	30402-4	12	5.0	0.18
304-08	14"	30408-6	12	5.0	0.18
304-19	14"	30419-2	12	5.0	0.18

BALL PEIN HAMMER HANDLES

Ball pein machinist hammer handles



Model	Length	UPC 0 25545 +	Pack qty	Pack wgt	Pack cube
-------	--------	------------------	-------------	-------------	--------------

For 2 oz. hammers, eye 7/16" x 1/4"

400-19	10"	40019-1	12	2.0	0.12
--------	-----	---------	----	-----	------

For 4 to 6 oz. hammers, eye 9/16" x 5/16"

401-19	10"	40119-8	12	2.5	0.12
--------	-----	---------	----	-----	------

For 8 to 12 oz. hammers, eye 3/4" x 7/16"

403-02	12"	40302-4	12	3.0	0.12
403-04	12"	40304-8	12	3.0	0.12
403-08	12"	40308-6	12	3.0	0.12
403-19	12"	40319-2	12	3.0	0.12

For 16 to 20 oz. hammers, 29/32" x 17/32"

405-02	14"	40502-8	12	4.0	0.18
405-04	14"	40504-2	12	4.0	0.18
405-08	14"	40508-0	12	4.0	0.18
405-19	14"	40519-6	12	4.0	0.18

BALL PEIN HAMMER HANDLES (cont.)

For 24 to 28 oz. hammers, 1-1/16" x 19/32"

407-02	16"	40702-2	12	5.0	0.21
407-04	16"	40704-6	12	5.0	0.21
407-08	16"	40708-4	12	5.0	0.21
407-19	16"	40719-0	12	5.0	0.21

For 32 to 48 oz. hammers, eye 1-3/16" x 11/16"

409-02	18"	40902-6	12	6.0	0.25
409-08	18"	40908-8	12	6.0	0.25
409-19	18"	40919-4	12	6.0	0.25

TIRE HAMMER HANDLES

Tire hammer handles for Ken Tool hammers



Model	Length	UPC 0 25545 +	Pack qty	Pack wgt	Pack cube
-------	--------	------------------	-------------	-------------	--------------

Safety grip, for T11, T11C, T34, T35, and T36, eye 1/13/16" x 1-15/16"

474-23	17"	47423-9	12	10.0	0.31
--------	-----	---------	----	------	------

Safety grip, for T11E, eye 1-13/16" x 1-11/16"

477-23	30"	47723-0	12	20.0	0.54
--------	-----	---------	----	------	------



Non-slip grip, for T11, T11C, T34, T35, and T36 eye 1-3/16" x 1-5/16"

474-55	17"	47455-0	12	10.0	0.31
477-55	30"	47755-1	12	20.0	0.54

SHORT SLEDGE AND OTHER HAMMER HANDLES

Engineer's or blacksmith hammer handles, oval eye



Model	Length	UPC 0 25545 +	Pack qty	Pack wgt	Pack cube
-------	--------	------------------	-------------	-------------	--------------

For 1-1/2 to 2-1/2 lb. hammers, eye 7/8" x 5/8"

435-19	12"	43519-3	12	4.0	0.18
421-02	14"	42102-8	12	4.0	0.22
421-19	14"	42119-6	12	4.0	0.22

For 3 to 4 lb. hammers, eye 1" x 3/4"

423-01	16"	42301-5	12	5.0	0.21
423-02	16"	42302-2	12	5.0	0.21
423-04	16"	42304-6	12	5.0	0.21
423-08	16"	42308-4	12	5.0	0.21
423-19	16"	42319-0	12	5.0	0.21

For 3 to 4 lb. hammers, eye 1" x 3/4"

424-19	18"	42419-7	12	6.0	0.25
--------	-----	---------	----	-----	------

For 3.5 lb. and heavier hammers, eye 1-1/4" x 1"

432-02	16"	43202-4	12	6.0	0.30
432-04	16"	43204-8	12	6.0	0.30
432-19	16"	43219-2	12	6.0	0.30

For 3.5 lb. and heavier hammers, eye 1-1/4" x 1"

433-02	18"	43302-1	12	7.0	0.33
433-04	18"	43304-6	12	7.0	0.33
433-08	18"	43308-3	12	7.0	0.33
433-19	18"	43319-9	12	7.0	0.33

Engineer's or blacksmith hammer handles, flat eye

For 2 to 3 lb. hammers, eye 1-3/16" x 11/16"



Model	Length	UPC 0 25545 +	Pack qty	Pack wgt	Pack cube
430-01	14"	43001-3	12	4.5	0.23
430-02	14"	43002-0	12	4.5	0.23
430-04	14"	43004-4	12	4.5	0.23
430-08	14"	43008-2	12	4.5	0.23
430-19	14"	43019-8	12	4.5	0.23

Brick hammer handles

For brick hammers and scutches, eye 1-1/16" x 19/32"



Model	Length	UPC 0 25545 +	Pack qty	Pack wgt	Pack cube
440-19	12"	44019-7	12	5.0	0.18

Stone mason hammer handles

Oval eye 1-1/8" x 5/8"



Model	Length	UPC 0 25545 +	Pack qty	Pack wgt	Pack cube
451-19	16"	45119-3	12	5.5	0.28

Hand drill and sledge hammer handles

For 2 to 4 lb. hammers, oval eye 1" x 3/4"



Model	Length	UPC 0 25545 +	Pack qty	Pack wgt	Pack cube
480-02	10-1/2"	48002-5	12	5.0	0.23
480-19	10-1/2"	48019-3	12	5.0	0.23
481-19	12"	48119-0	12	6.0	0.21

SHORT SLEDGE AND OTHER HAMMER HANDLES (cont.)

Straight California framing hammer handles



Model	Length	UPC 0 25545 +	Pack qty	Pack wgt	Pack cube
-------	--------	------------------	-------------	-------------	--------------

For 23 oz. Hart hammers, eye 1-5/8" x 11/16"

1172-02	18"	00643-3	12	6.0	0.33
1172-04	18"	00593-8	12	6.0	0.33

For 23 oz. Vaughn & Bushnell hammers, eye 1-11/16" x 11/16"

6321-19	18"	03957-5	12	6.0	0.33
---------	-----	---------	----	-----	------

Curved California framing hammer handles

For 25 oz. hammers, eye 1-11/16" x 11/16"



Model	Length	UPC 0 25545 +	Pack qty	Pack wgt	Pack cube
7078-19	18"	06493-5	12	7.0	0.33

Rig builder's (rigster) hatchet handles

For rig hatchets, eye 1-9/16" x 5/8"



Model	Length	UPC 0 25545 +	Pack qty	Pack wgt	Pack cube
365-02	18"	36502-5	12	7.0	0.33
365-19	18"	36519-3	12	7.0	0.33

Boy Scout axe handles



Model	Length	UPC 0 25545 +	Pack qty	Pack wgt	Pack cube
-------	--------	------------------	-------------	-------------	--------------

For 1-1/4 lb. axes, eye 1-5/8" x 19/32"

368-02	14"	36802-6	12	6.0	0.28
368-04	14"	36804-0	12	6.0	0.28
368-08	14"	36808-8	12	6.0	0.28
368-19	14"	36819-4	12	6.0	0.28

For 1-3/4 lb. axes, 1-3/4" x 11/16"

369-19	16"	36919-1	12	7.0	0.33
--------	-----	---------	----	-----	------

HATCHET HANDLES

Hatchet handles



Model	Length	UPC 0 25545 +	Pack qty	Pack wgt	Pack cube
-------	--------	------------------	-------------	-------------	--------------

For No. 2 shingling, half-hatchet, claw, and No. 1 broad hatchets, eye 1-19/32" x 19/32"

330-02	14"	33002-3	12	6.0	0.23
330-04	14"	33004-7	12	6.0	0.23
330-08	14"	33008-5	12	6.0	0.23
330-19	14"	33019-1	12	6.0	0.23

For No. 3 and 4 broad hatchets and linesmen's hatchets, eye 1-13/16" x 5/8"

334-04	16"	33404-5	12	8.0	0.28
334-19	16"	33419-9	12	8.0	0.28

Plumb expert hatchet handles

For plumb, box, wallboard, and California lathe hatchets eye 1-1/4" x 1/2"



Model	Length	UPC 0 25545 +	Pack qty	Pack wgt	Pack cube
350-02	14"	35002-1	12	5.0	0.23
350-19	14"	35019-9	12	5.0	0.23

FILE HANDLES

Long ferrule file handles



Model	Length	UPC 0 25545 +	Pack qty	Pack wgt	Pack cube
-------	--------	------------------	-------------	-------------	--------------

4" x 1" (size No. 1) for 3" to 6" files

29541-00	4"	00018-6	36	2.0	0.06
----------	----	---------	----	-----	------

4-1/2" x 1-3/16" (size No. 2) for 6" to 8" files

29542-00	4-1/2"	00019-3	36	4.0	0.10
----------	--------	---------	----	-----	------

5" x 1-5/16" (size No. 3) for 8" to 12" files

29543-00	5"	00020-9	36	5.3	0.12
----------	----	---------	----	-----	------

5-1/2" x 1-7/16" (size No. 4) for 12" to 16" files

29544-00	5-1/2"	00021-6	36	7.0	0.18
----------	--------	---------	----	-----	------

6" x 1-9/16" (size No. 5) for 16" to 20" files

29545-00	6"	00022-3	36	9.0	0.21
----------	----	---------	----	-----	------

FILE HANDLES (cont.)

Short ferrule file handles



Model	Length	UPC 0 25545 +	Pack qty	Pack wgt	Pack cube
3-1/2" x 13/16" (size No. 00), bore 1/8", for chain saws					
31559-00	3-1/2"	00024-7	36	1.5	0.12
3-1/2" x 13/16" (size No. 01), bore 5/32", for 3" to 4" files					
31561-00	3-1/2"	00025-4	36	1.5	0.12
4" x 15/16" (size No. 02), bore 3/16", for 4" to 6" files					
31562-00	4"	00026-1	36	2.0	0.09
4-1/4" x 1-3/64" (size No. 03), bore 7/32", for 6" to 8" files					
31563-00	4-1/4"	00027-8	36	2.5	0.12
4-3/4" x 1-1/8" (size No. 04), bore 9/32", for 8" to 10" files					
31564-00	4-3/4"	00028-5	36	3.5	0.15
5" x 1-1/4" (size No. 05), bore 3/8", for 10" to 14" files					
31565-00	5"	00029-2	36	4.0	0.14

TiteGrip screw-on file handles

A screw on handle that makes its own thread on tang of file



Model	Length	UPC 0 25545 +	Pack qty	Pack wgt	Pack cube
For 4" files					
30571-00		00032-2	36	1.5	0.05
For 5" files					
30572-00		00033-9	36	3.0	0.09
For 6" files					
30569-00		00034-6	36	3.0	0.07
For 8" files					
30573-00		00035-3	36	5.0	0.13
For 10" files					
30574-00		00036-0	36	5.0	0.13
For 12" files and rasps					
30576-00		00037-7	36	7.3	0.19
For 14" files and rasps					
30575-00		00038-4	36	7.3	0.19

No. 10 file card

The sharp steel bristles quickly remove filings from file grooves



Model	Length	UPC 0 25545 +	Pack qty	Pack wgt	Pack cube
324-00	8"	32400-8	12	2.0	0.07

HANDLE WEDGES

Wood and steel wedges

Each package contains 1 wood wedge and 2 steel wedges. Color coded for display. Includes step-by-step instructions and diagrams.



Model	Color	UPC 0 25545 +	Pac qty	Pack wgt	Pack cube
Hammer handle wedges					
04510-00	Blue	00001-8	24	1.3	0.12
Hatchet handle wedges					
04511-00	Green	00002-5	24	1.3	0.12
Sledge and maul handle wedges					
04512-00	Red	00003-2	24	1.5	0.12
Axe handle wedges					
04513-00	Brown	00004-9	24	2.0	0.12
Assortment of 24 wood and steel wedges (6 each of 4 sizes)					
04514-00		00005-6	1	1.8	

Corrugated steel wedges



Model	Package wgt	UPC 0 25545 +	Pack qty	Pack wgt	Pack cube
Hammer handle wedges, No. 2, 5/16" W x 13/16" H, 36 per package					
50-490	3 oz.	00006-3	1	0.2	0.07
Carpenter's hammer handle wedges, No. 3, 1/2" W x 1-1/16" H, 36 per package					
50-491	9 oz.	00007-0	1	0.6	0.07
Large hammer handle wedges, No. 4, 3/4" W x 1-1/16" H, 36 per package					
50-492	10 oz.	00008-7	1	0.6	0.07
Sledge hammer handle wedges, No. 5, 1" W x 1-1/16" H, 36 per package					
50-493	12 oz.	00009-4	1	0.8	0.07
Axe handle wedges, No. 18, 1-1/4" W x 1-3/16" H, 12 per package					
50-494	10 oz.	00010-0	1	0.6	0.07

HANDLE WEDGES (cont.)

Steel wedge and rivet assortment in counter display



Assortment includes 252 pieces plus display box. Contains 12 LR1 and 12 LR2 round wedges; 36 #2, 36 #3, 36 #4, 36 #5, and 12 #18 flat steel wedges; plus 72 rivets.

Model	UPC 0 25545 +	Pack qty	Pack wgt	Pack cube
50-497	00011-7	1	3.0	0.07

Wood wedges

Each package contains 12 wood wedges. Includes step-by-step instructions and diagrams.



Model	Package wgt	UPC 0 25545 +	Pack qty	Pack wgt	Pack cube
Single bit axe handle wedges, No. 2WW, 2-1/2" W x 2-1/2" H					
13-390	5.0	00012-4	12	2.1	0.18
Sledge handle wedges, No. 3WW, 1-3/8" W x 2-1/2" H					
13-391	2.7	00013-1	12	1.3	0.18
Machinist hammer handle wedges, No. 4WW, 1-1/16" W x 1-1/2" H					
13-392	0.8	00014-8	12	0.5	0.08
Hatchet handle wedges, No. 8WW, 1-5/8" W x 2" H					
13-393	3.4	00015-5	12	1.6	0.18
Double bit axe handle wedges, No. 9WW, 3" W x 2-1/2" H					
13-394	5.5	00016-2	12	2.5	0.18
Nail hammer handle wedges, No. 10WW, 1-3/16" W x 1-1/2" H					
13-395	0.8	00017-9	12	0.5	0.08

Round (cone-shaped) steel wedges

- ◆ Expands wood equally in all directions for tightest fit.
- ◆ Provides better holding power than flat wedges.
- ◆ Eliminates need for flat wood and steel wedges.
- ◆ Two sizes fit every need.

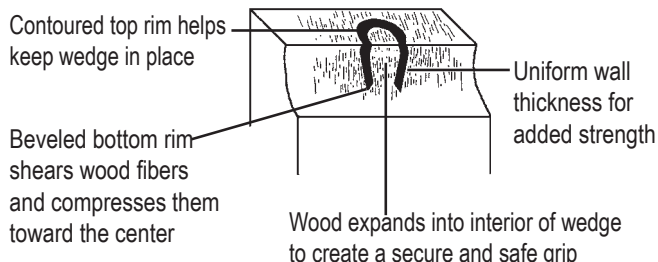

Round steel wedges, retail pack

Each retail package contains 2 round steel wedges. Includes step-by-step instructions and diagrams.



Model	Package wgt	UPC 0 25545 +	Pack qty	Pack wgt	Pack cube
LR1 round steel wedges, 9/16" H x 9/16" diameter					
06903-00	0.7	06903-9	6	0.5	0.08
LR2 round steel wedges, 3/4" H x 3/4" diameter					
06905-00	1.1	16905-0	6	0.6	0.08

Round steel wedges, bulk pack

Each bulk package contains 12 round steel wedges.



Model	Package wgt	UPC 0 25545 +	Pack qty	Pack wgt	Pack cube
LR1 round steel wedges, 9/16" H x 9/16" diameter					
06904-00	3.7	16904-3	12	1.5	0.05
LR2 round steel wedges, 3/4" H x 3/4" diameter					
06906-00	6.1	16906-7	12	2.4	0.05

FIBERGLASS HANDLES *NON-DOMESTIC PRODUCT

Heavy-duty fiberglass handles.

Sledge and maul fiberglass handle

For 6 to 16 lb. and some 18 to 24 lb. sledges and mauls. Handle comes with epoxy kit.



Model	Length	UPC 0 25545 +	Pack qty	Pack wgt	Pack cube
001-99	34"	00199-2	6	13.0	0.74

Single bit axe fiberglass handle

For 3 to 5 lb. single bit axes. Handle comes with epoxy kit.



Model	Length	UPC 0 25545 +	Pack qty	Pack wgt	Pack cube
100-99	34"	10099-2	6	14.0	0.92

Double bit axe fiberglass handle

For 3 to 5 lb. double bit axes. Handle comes with epoxy kit.



Model	Length	UPC 0 25545 +	Pack qty	Pack wgt	Pack cube
140-99	34"	06932-9	6	14.0	0.92

Railroad and garden pick fiberglass handle

For railroad No. 6 eye picks and mattocks and 2.5 lb. garden pick mattock. Centrifugal force tightens head so no epoxy needed.



Model	Length	UPC 0 25545 +	Pack qty	Pack wgt	Pack cube
220-99	36"	06933-6	6	16.0	1.37

Railroad and garden pick fiberglass handle

For railroad No. 10 eye picks and mattocks and 2.5 lb. garden pick mattock. Centrifugal force tightens head so no epoxy needed.



Model	Length	UPC 0 25545 +	Pack qty	Pack wgt	Pack cube
221-99	36"	22199-4	6	16.0	1.30

Claw hammer fiberglass handle

Handle comes with epoxy kit.



Model	Length	UPC 0 25545 +	Pack qty	Pack wgt	Pack cube
300-99	14"	06929-9	6	4.0	0.20

Engineer's and blacksmith's hammer fiberglass handle

Handle comes with epoxy kit.



Model	Length	UPC 0 25545 +	Pack qty	Pack wgt	Pack cube
423-99	15"	42399-2	6	7.0	0.20

Shovel fiberglass handle

For hollowback and closed back shovels. Handle comes with rivet.



Model	Length	UPC 0 25545 +	Pack qty	Pack wgt	Pack cube
870-99	46"	06940-4	6	14.0	0.53

D-grip shovel fiberglass handle

For D-grip hollowback and closed back shovels.

Handle comes with rivet.



Model	Length	UPC 0 25545 +	Pack qty	Pack wgt	Pack cube
871-99	27"	06931-2	6	10.0	0.68

Epoxy kit

For attaching fiberglass handles



Model	Length	UPC 0 25545 +	Pack qty	Pack wgt	Pack cube
7001-00		04033-5	6	2.0	0.11

FORK HANDLES

Straight hay fork handles

1-7/16" diameter, 7/16" bore, 8" ferrule



Model	Length	UPC 0 25545 +	Pack qty	Pack wgt	Pack cube
700-21	48"	70021-5	6	11	0.53
701-21	54"	70121-2	6	12	0.51
702-21	60"	70221-9	6	14	0.55

Bent hay, 3-tine header, and alfalfa fork handles

1-7/16" diameter, 7/16" bore, 8" ferrule



Model	Length	UPC 0 25545 +	Pack qty	Pack wgt	Pack cube
706-21	48"	70621-7	6	11	0.53
707-21	54"	70721-4	6	12	0.61
708-21	60"	70821-1	6	14	0.55

Bent manure and barley fork handles

1-7/16" diameter, 1/2" bore, 8" ferrule



Model	Length	UPC 0 25545 +	Pack qty	Pack wgt	Pack cube
715-18	48"	71518-9	6	11	0.53
715-21	48"	71521-9	6	11	0.53
716-21	54"	71621-6	6	12	0.61
717-21	60"	71721-3	6	13	0.55

Bent spading fork handles

1-1/2" diameter, 5/8" bore, 8" ferrule



Model	Length	UPC 0 25545 +	Pack qty	Pack wgt	Pack cube
711-21	48"	71121-1	6	13	0.53
922-21	54"	92221-1	6	14	0.61

Bent spading fork handle, steel D-grip

1-1/2" diameter, 5/8" bore, 8" ferrule



Model	Length	UPC 0 25545 +	Pack qty	Pack wgt	Pack cube
730-21	30"	73021-2	6	13	0.68

Bent manure fork, clam fork, barley fork, and sod lifter handles, steel D-grip



Model	Length	UPC 0 25545 +	Pack qty	Pack wgt	Pack cube
1-1/2" diameter, 1/2" bore x 3", 8" ferrule					
731-21	32"	73121-9	6	13	0.68
1-1/2" diameter, 5/8" bore x 3", 8" ferrule					
736-21	36"	73621-4	6	14	0.68

Bent seed, coke, ensilage, and heavy manure fork handles, steel D-grip

1-1/2" diameter, 11/16" bore, 8" ferrule



Model	Length	UPC 0 25545 +	Pack qty	Pack wgt	Pack cube
728-21	30"	72821-9	6	13	0.68
734-21	32"	73421-0	6	14	0.68

HOE & HOOK HANDLES

Eye hoe and fire rake handle

1-3/4" round eye



Model	Length	UPC 0 25545 +	Pack qty	Pack wgt	Pack cube
810-21	54"	81021-1	6	11	0.77
811-18	60"	81118-8	6	12	0.86
811-21	60"	81121-8	6	12	0.86

Potato hook handles

1-7/16" diameter, 1/2" bore, 4" ferrule



Model	Length	UPC 0 25545 +	Pack qty	Pack wgt	Pack cube
977-21	48"	97721-1	6	10	0.55
978-21	54"	97821-8	6	11	0.61

AMERICAN ASH

Provides the strength and the elasticity needed for the stresses these tools must endure

HOE & HOOK HANDLES (cont.)

Garden hoe handles

1-1/4" diameter, 3/8" bore, 4" ferrule. Also used for meadow hoes, light cotton hoes, light scuffle hoes, light hooks, stone hooks, and light potato hooks.



Model	Length	UPC 0 25545 +	Pack qty	Pack wgt	Pack cube
741-21	48"	74121-8	6	8	0.98
742-21	52"	74221-5	6	8	0.50
743-21	54"	74321-2	6	9	0.50
744-21	60"	74421-9	6	9	0.55

Garden hoe, meadow hoe, light cotton hoe handles

1-1/4" diameter, 3/8" bore, chucked



Model	Length	UPC 0 25545 +	Pack qty	Pack wgt	Pack cube
746-21	52"	74621-3	6	8	0.50
747-21	54"	74721-0	6	8	0.50
748-21	60"	74821-7	6	9	0.55

Socket pattern hoe handles

1-1/4" diameter, chucked



Model	Length	UPC 0 25545 +	Pack qty	Pack wgt	Pack cube
756-21	52"	75621-2	6	8	0.50
757-21	54"	75721-9	6	8	0.50
758-21	60"	75821-6	6	9	0.55

Heavy cotton hoe and scraper handles, with ferrules

1-3/8" diameter, 7/16" bore, chucked, 4" ferrule



Model	Length	UPC 0 25545 +	Pack qty	Pack wgt	Pack cube
752-21	54"	75221-4	6	9	0.50
753-21	60"	75321-1	6	11	0.55

Heavy cotton hoe handle, without ferrule

1-3/8" diameter, 7/16" bore, chucked, no ferrule



Model	Length	UPC 0 25545 +	Pack qty	Pack wgt	Pack cube
760-21	54"	76021-9	6	8	0.50

Planter's hoe handle

1-7/16" diameter, 9/16" bore, 4" ferrule



Model	Length	UPC 0 25545 +	Pack qty	Pack wgt	Pack cube
739-21	60"	73921-5	6	11	0.55

Mortar hoe, scuffle hoe, heavy hook, road rake, asphalt rake, tar rake, etc. handle

1-7/16" diameter, 9/16" bore, chucked, 8" ferrule



Model	Length	UPC 0 25545 +	Pack qty	Pack wgt	Pack cube
765-21	60"	76521-4	6	15	0.55
767-21	72"	76721-8	6	17	0.55

Mortar hoe, scuffle hoe, heavy hook, road rake, and pine needle rake handle

1-7/16" diameter, 9/16" bore, 4" ferrule



Model	Length	UPC 0 25545 +	Pack qty	Pack wgt	Pack cube
780-21	60"	78021-7	6	30	0.55

Heavy socket cotton hoe & sidewalk scraper handle

1-3/8" diameter, chucked



Model	Length	UPC 0 25545 +	Pack qty	Pack wgt	Pack cube
924-21	60"	92421-5	6	10	0.55

RAKE HANDLES *NON-DOMESTIC PRODUCT

Lawn and leaf rake handles

15/16" diameter, 2-1/2" chuck to 5/8"



Model	Length	UPC 0 25545 +	Pack qty	Pack wgt	Pack cube
22-342	42"	05385-4	6	5	0.98
22-348	48"	04806-5	6	6	0.98
22-351	51"	04803-4	6	6	0.29
22-360	60"	05095-2	6	7	0.86

Lawn and leaf rake handles

15/16" diameter, straight end, 9/32" cross drill 1-5/8" from end



Model	Length	UPC 0 25545 +	Pack qty	Pack wgt	Pack cube
22-604	54"	05240-6	12	11.2	1.06

RAKE HANDLES (cont.) *NON-DOMESTIC PRODUCT

Level head rake and garden hoe handle

1-1/4" diameter, 3/8" bore, turned end ferrule



Model	Length	UPC 0 25545 +	Pack qty	Pack wgt	Pack cube
790-21	60"	79021-6	6	10	0.55

Level head rake handle

1-1/4" diameter, 3/8" bore, chucked



Model	Length	UPC 0 25545 +	Pack qty	Pack wgt	Pack cube
794-21	60"	79421-4	6	9	0.55

Bow rake handle

1-1/4" diameter, 4" ferrule, 7/16" bore



Model	Length	UPC 0 25545 +	Pack qty	Pack wgt	Pack cube
797-21	60"	79721-5	6	10	0.55

SCRAPER HANDLES

Sidewalk scraper handle

1-3/8" socket style, 3-7/8" chuck



Model	Length	UPC 0 25545 +	Pack qty	Pack wgt	Pack cube
905-21	48"	90521-4	6	9	0.53

Barn scraper handle

1-7/16" diameter, 7/16" bore, 8" ferrule



Model	Length	UPC 0 25545 +	Pack qty	Pack wgt	Pack cube
930-21	60"	93021-6	6	15	0.86

AUGER, DRAIN TILE AND POSTHOLE DIGGER HANDLES

Auger handle

For augers with cross T handles



Model	Length	UPC 0 25545 +	Pack qty	Pack wgt	Pack cube
22-027	21"	04848-5	6	2	0.68

Drain tile cleaner handle

For all size drain cleaners



Model	Length	UPC 0 25545 +	Pack qty	Pack wgt	Pack cube
22-076	72"	04877-5	6	2	0.95

Square eye posthole digger handles

For Atlas, Hercules, and similar posthole diggers, drilled



Model	Length	UPC 0 25545 +	Pack qty	Pack wgt	Pack cube
863-18	48"	86318-7	6	10	0.53
863-21	48"	86321-7	6	10	0.53
866-21	72"	86621-8	6	17	0.95
867-21	96"	86721-5	6	20	0.76

Round end posthole digger handles

Drilled



Model	Length	UPC 0 25545 +	Pack qty	Pack wgt	Pack cube
864-18	48"	86418-4	6	10	0.53
864-21	48"	86421-4	6	10	0.53

Posthole digger handles

For Eureka posthole diggers



Model	Length	UPC 0 25545 +	Pack qty	Pack wgt	Pack cube
865-21	48"	86521-1	6	10	0.53

PRUNING TOOL HANDLES

Hedge shear handles

21/32" bore, ferruled



Model	Length	UPC 0 25545 +	Pack qty	Pack wgt	Pack cube
22-023	10"	04845-4	6	2	1.18

Lopping shear handles

4" ferrule, 1/2" bore



Model	Length	UPC 0 25545 +	Pack qty	Pack wgt	Pack cube
22-033	24"	04854-6	6	5	1.18

PLOW HANDLE

Plow handle

56" walking plow handle, red oak

Model	Length	UPC 0 25545 + 05115-7	Pack qty	Pack wgt	Pack cube
22-388	56"		2	3.2	1.79

WHEELBARROW HANDLES & WEDGES

Wheelbarrow handles



Model	Length	UPC 0 25545 +	Pack qty	Pack wgt	Pack cube
1-3/8" x 1-3/4", straight pattern, parallel end to end, shaped grip end, clear finish					
35-025	60"	04769-3	6	27	0.86

Model	Length	UPC 0 25545 +	Pack qty	Pack wgt	Pack cube
1-3/8" x 1-3/4", straight pattern, parallel end to end, shaped grip end, sand finish					
36-025	60"	04771-6	6	27	0.86

Model	Length	UPC 0 25545 +	Pack qty	Pack wgt	Pack cube
1-3/8" x 1-3/4", straight pattern, parallel end to end, shaped grip end, no bore, sand finish, homeowner quality					
35-029	54"	05473-8	6	23	1.06

Wheelbarrow wedges, clear finish



Model	Length	UPC 0 25545 +	Pack qty	Pack wgt	Pack cube
35-026	24"	04770-9	6	5	1.18

PAINT ROLLER, SQUEEGEE, AND PUSH BROOM HANDLES *NON-DOMESTIC PRODUCT

Push broom and squeegee handles, tapered end

1-1/8" diameter, tapered to 3/4" within 3"



Model	Length	UPC 0 25545 +	Pack qty	Pack wgt	Pack cube
22-245	54"	04809-6	12	11	0.86
22-250	60"	04810-2	12	15	0.86

Push broom handles, metal thread

15/16" diameter, 3/4" Acme metal thread



Model	Length	UPC 0 25545 +	Pack qty	Pack wgt	Pack cube
22-299	54"	05042-6	12	13	1.06
22-300	60"	04802-7	12	15	0.55

Push broom handles, wood thread

15/16" diameter, 3/4" Acme wood thread



Model	Length	UPC 0 25545 +	Pack qty	Pack wgt	Pack cube
22-350	60"	04811-9	12	14	0.86

WEED CUTTER HANDLES

Weed cutter handle



Model	Length	UPC 0 25545 +	Pack qty	Pack wgt	Pack cube
7248-00	30"	04123-3	12	15	1.18

Turf edger handle



Model	Length	UPC 0 25545 +	Pack qty	Pack wgt	Pack cube
22-025	48"	04846-1	12	12	0.53

TAMPER HANDLES

Shaped tamper handle

1-7/16" diameter, straight eye, sanded finish



Model	Length	UPC 0 25545 +	Pack qty	Pack wgt	Pack cube
39652-21	44"	00582-2	6	2.5	0.53

Unshaped tamper handle

1-1/2" diameter, straight eye, sanded finish



Model	Length	UPC 0 25545 +	Pack qty	Pack wgt	Pack cube
No slot					
39658-21	48"	00588-4	6	1.8	0.53
39659-21	42"	00589-1	6	1.5	0.53
With single 2" slot					
49658-21	48"	00852-6	6	1.8	0.53
49659-21	42"	05851-4	6	1.5	0.53

BENT HOLLOWBACK SHOVEL HANDLES WITH SHOULDER

Long bent hollowback shovel/scoop handles with shoulder

1-1/2" diameter, 9" chuck with slot



Model	Length	UPC 0 25545 +	Pack qty	Pack wgt	Pack cube
827-18	48"	82718-9	6	10	0.53
827-21	48"	82721-9	6	10	0.53
828-21	54"	82821-6	6	12	0.61

BENT HOLLOWBACK SHOVEL HANDLES WITH SHOULDER (cont..)

Bent hollowback shovel/scoop handles with shoulder, steel D-grip

1-1/2" diameter, 9" chuck with slot



Model	Length	UPC 0 25545 +	Pack qty	Pack wgt	Pack cube
829-18	30"	82918-3	6	10	0.68
829-21	30"	82921-3	6	10	0.68
960-21	36"	96021-3	6	12	0.53
892-21	38"	89221-7	6	12	0.53
876-21	42"	87621-7	6	13	0.53

BENT HOLLOWBACK SHOVEL HANDLES WITHOUT SHOULDER

Long bent hollowback shovel/scoop handles without shoulder

1-1/2" diameter, 9-1/2" eye chuck, eye slot



Model	Length	UPC 0 25545 +	Pack qty	Pack wgt	Pack cube
823-18	48"	82318-1	6	10	0.53
823-21	48"	82321-1	6	10	0.53
824-21	54"	82421-8	6	12	0.61

Bent hollowback shovel handles without shoulder, steel D-grip

1-1/2" diameter, 9-1/2" eye chuck, eye slot



Model	Length	UPC 0 25545 +	Pack qty	Pack wgt	Pack cube
825-21	30"	82521-5	6	10	0.68

STRAIGHT HOLLOWBACK SHOVEL HANDLES WITH SHOULDER

Long straight hollowback floral shovel handles with shoulder

1-7/16" diameter, 9" chuck with slot



Model	Length	UPC 0 25545 +	Pack qty	Pack wgt	Pack cube
750-21	42"	75021-0	6	7	0.53

Long straight hollowback shovel/scoop handles with shoulder

1-1/2" diameter, 9" chuck with slot



Model	Length	UPC 0 25545 +	Pack qty	Pack wgt	Pack cube
870-21	48"	87021-5	6	10	0.53
880-21	54"	88021-4	6	11	0.61

Straight hollowback shovel/scoop handles with shoulder, steel D-grip

1-1/2" diameter, 9" chuck with slot



Model	Length	UPC 0 25545 +	Pack qty	Pack wgt	Pack cube
871-21	30"	87121-2	6	10	0.68
789-21	38"	78921-0	6	13	0.68

STRAIGHT HOLLOWBACK SHOVEL HANDLES WITHOUT SHOULDER

Straight hollowback shovel handles without shoulder, steel D-grip

1-1/2" diameter, 9-1/2" chuck with slot



Model	Length	UPC 0 25545 +	Pack qty	Pack wgt	Pack cube
873-21	30"	87321-6	6	10	0.68

Long straight hollowback shovel handles without shoulder

1-1/2" diameter, 9-1/2" chuck with slot



Model	Length	UPC 0 25545 +	Pack qty	Pack wgt	Pack cube
881-21	48"	88121-1	6	10	0.53

AMERICAN ASH
Provides the strength and the elasticity needed for the stresses these tools must endure

CLOSED BACK SHOVEL HANDLES WITH SHOULDER

Closed back solid shank shovel and spade handles with shoulder, steel D-grip

1-1/2" diameter, 6-1/2" chuck, regular weight



Model	Length	UPC 0 25545 +	Pack qty	Pack wgt	Pack cube
834-21	24"	83421-7	6	8	0.68

Closed back solid shank shovel and spade handles with shoulder

1-1/2" diameter, 5-1/2" chuck, featherweight



Model	Length	UPC 0 25545 +	Pack qty	Pack wgt	Pack cube
836-21	44-1/2"	83621-1	6	8	0.68

Closed back solid shank shovel and spade handles with shoulder, steel D-grip

1-1/2" diameter, 5-1/2" chuck, featherweight



Model	Length	UPC 0 25545 +	Pack qty	Pack wgt	Pack cube
838-21	24"	83821-5	6	8	0.68

Closed back solid shank shovel and spade handles with shoulder

1-1/2" diameter, 6-1/2" chuck



Model	Length	UPC 0 25545 +	Pack qty	Pack wgt	Pack cube
896-21	44-1/2"	89621-5	6	8	0.53
897-21	46-1/2"	89721-2	6	9	0.53
898-21	48"	89821-9	6	10	0.53

General purpose shovel handle with shoulder
1-1/2" diameter



Model	Length	UPC 0 25545 +	Pack qty	Pack wgt	Pack cube
990-21	48"	99021-0	6	9	0.53

CLOSED BACK SHOVEL HANDLES WITHOUT SHOULDER

Closed back solid shank shovel handles without shoulder, steel D-grip

1-1/2" diameter, 4-1/2" chuck



Model	Length	UPC 0 25545 +	Pack qty	Pack wgt	Pack cube
807-21	24"	80721-1	6	9	0.68
808-21	25-1/2"	80821-8	6	9	0.68

Closed back solid shank shovel handles without shoulder

1-1/2" diameter, 4-1/2" chuck



Model	Length	UPC 0 25545 +	Pack qty	Pack wgt	Pack cube
844-21	44-1/2"	84421-6	6	9	0.53
841-21	46-1/2"	84121-5	6	9.5	0.53
842-21	48"	84221-2	6	10	0.53

Closed back solid shank shovel handles without shoulder

1-1/2" diameter, 5-1/2" chuck



Model	Length	UPC 0 25545 +	Pack qty	Pack wgt	Pack cube
989-21	44"	98921-4	6	9	0.86
950-21	48"	95021-4	6	10	0.53

Closed back solid shank shovel handles without shoulder, steel D-grip

1-1/2" diameter, 5-1/2" chuck



Model	Length	UPC 0 25545 +	Pack qty	Pack wgt	Pack cube
951-21	24"	95121-1	6	8	0.68
952-21	27"	95221-8	6	9	0.68
953-21	30"	95321-8	6	10	0.68

AMERICAN ASH
Provides the strength and the elasticity needed for the stresses these tools must endure

D-GRIPS

Tubular steel D-grip

Rugged steel D-grips are designed to provide the best combination of balance, grip, and comfort. Sized to provide the best grip for both gloved and ungloved hands.



Model	UPC	Pack qty	Pack wgt	Pack cube
50001-00	0 25545 + 00048-3	12	10	0.45

Poly D-grip

Extra-large D-grip handle designed to provide more room for gloved hands. Solid polypropylene grip is light weight yet durable. 1-1/4" diameter socket.



Model	UPC	Pack qty	Pack wgt	Pack cube
50025-00	0 25545 + 05492-9	12	8	0.40

IRON RIVETS

Iron rivets* for shovel handles

Rivets are furnished with each shovel handle. It is wise, however, to have extra rivets on hand.

3/16" diameter, 1-3/4" long



Model	UPC	Pack qty	Pack wgt	Pack cube
50005-00	0 25545 + 00052-0	1	8 oz.	0.08
50006-00	00053-7	1	1 oz.	0.04

* (50006-00 contains 4 rivets per package, 50005-00 has 36)

OUR SAWMILL LOCATIONS



SEYMOUR, IN



SEQUATCHIE, TN



CROSSVILLE, TN



ALTAMONT, TN

BETTER BY DESIGN

When your customers buy tool handles, they need handles with proper fit. The handle becomes an extension of their bodies and determines the comfort of the user. Link handles provide the time tested ergonomic shape and design that allows for better control, comfort, and safety.

LINK HANDLES® - Common handle eye shapes

Claw hammers, 16 oz.



1-1/16" X 9/16"



Handle models
300
304

Claw hammers, 20 to 24 oz.



1-1/16" X 5/8"



Handle models
310
312
313

Claw hammers, 28 to 32 oz.



1-3/16" X 3/4"



Handle models
321
322

Ball pein hammers, 16 to 20 oz.



29/32" X 17/32"

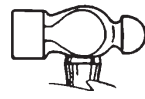

Handle models
405

Ball pein hammers, 24 to 28 oz.



1-1/16" X 19/32"

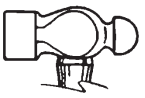

Handle models
407

Engineer or blacksmith or drilling hammers



1" X 3/4"



Handle models
423
424
480
481

Blacksmith hammers, 3-1/2 lb. and heavier

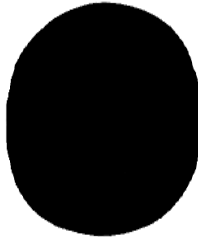

1-1/4" X 1"



Handle models
432
433

Sledges and mauls, 6 to 16 lb., oval eye



1-1/4" X 1"

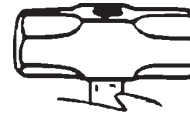

Handle models
001 003
002 004

Sledges and mauls, 18 to 24 lb.

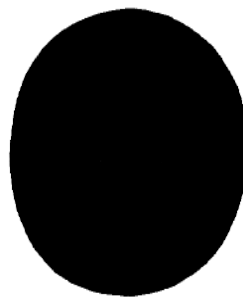

1-1/2" X 1-1/4"



Handle models
010
023

Splitting mauls, No. 5 eye

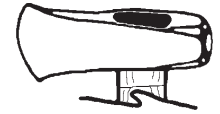

Handle models
205

2-1/8" X 7/8"

Single bit splitting mauls

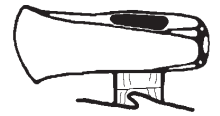

Handle models
206

2-5/16" X 13/16"

Scout or hunter axes, 1-3/4 lb.



Handle models
369
1-3/4" X 11/16"

Double-bit axes, 3-5 lb.



Handle models
140
142

2-7/8" X 5/8"

Scout axes, 1-1/4 lb.



Handle models
368
1-11/16" X 5/8"

LINK HANDLES® - Common handle eye shapes

Broad hatchets

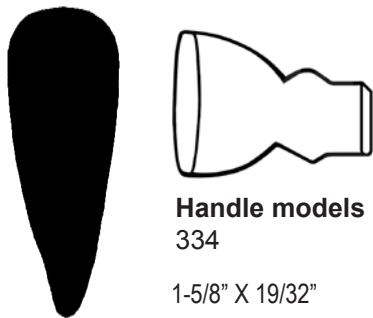

Handle models
334

1-5/8" X 19/32"

Half hatchets

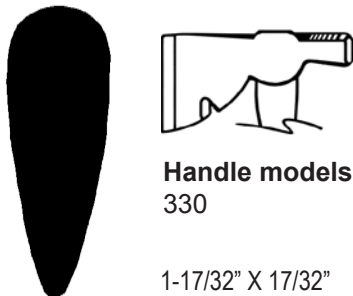

Handle models
330

1-17/32" X 17/32"

Grub hoes, No. 8 eye

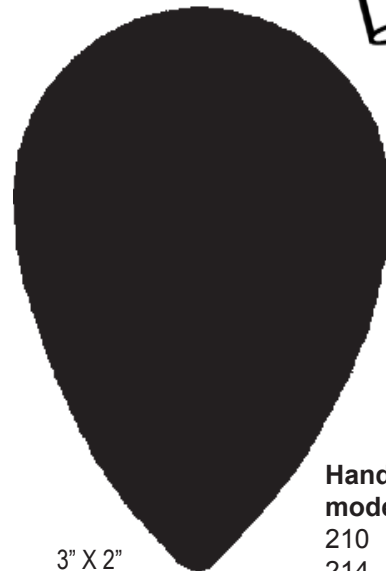

Handle models
210
214
215

3" X 2"

Railroad or clay picks & mattocks No. 6 eye

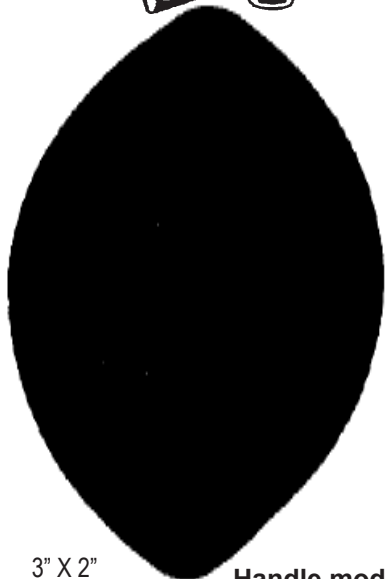

3" X 2"

Handle models
220

Garden or nursery mattocks, No. 7 eye

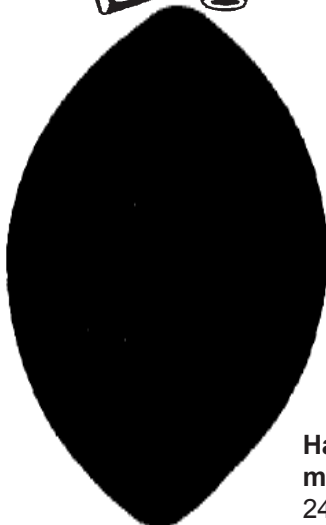

2-3/4" X 1-3/4"

Handle models
240

Small eye grub hoes, No. 9 eye



2-1/2" X 1-7/8"

Handle models
216

Carpenter's adze



2-5/16" X 1-1/2"



Handle models
224

Double bit garden mattocks, No. 10 eye

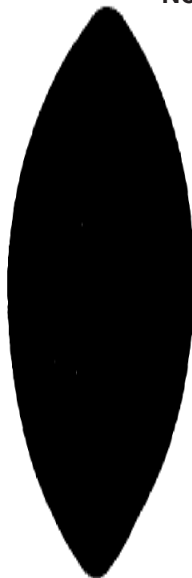
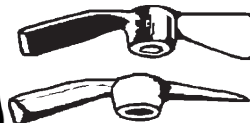

Handle models
200

3" X 1"

LINK HANDLES® - How to replace handles

Hammer & hand axe handles

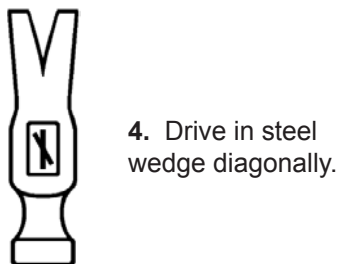
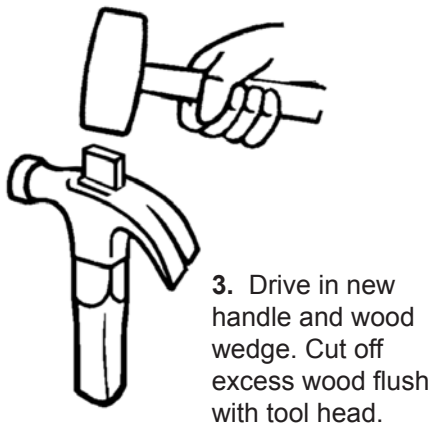
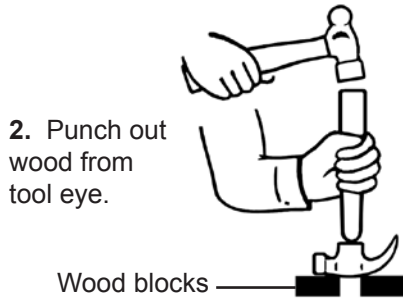
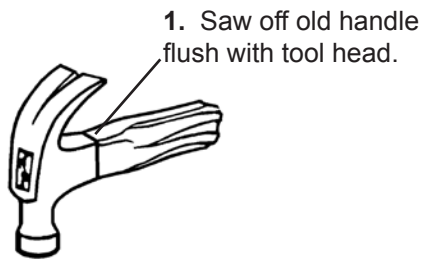

Sledge & axe handles

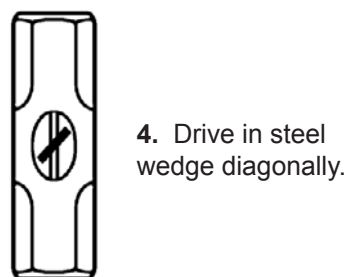
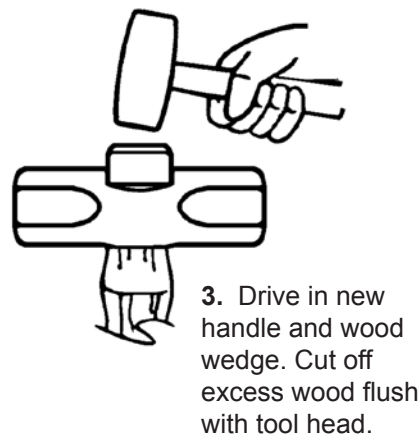
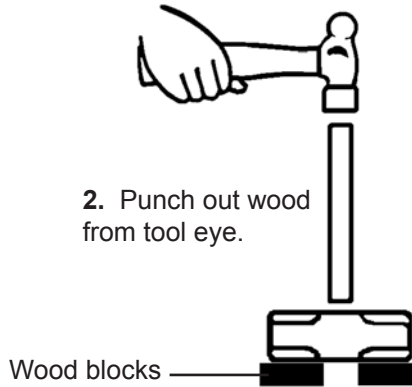
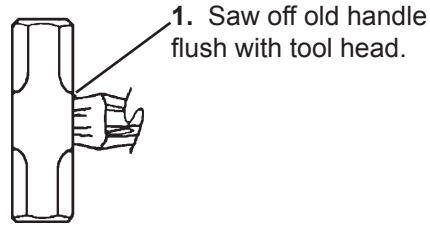

Mattock & eye hoe handles

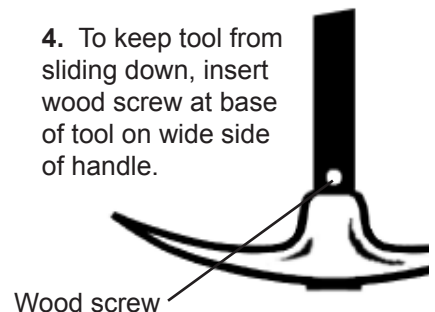
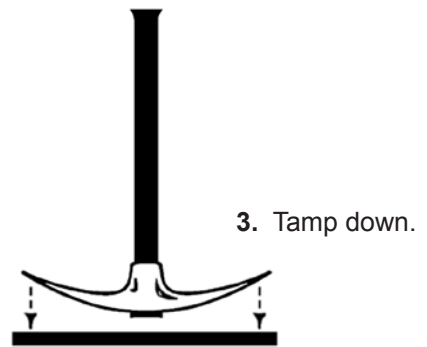
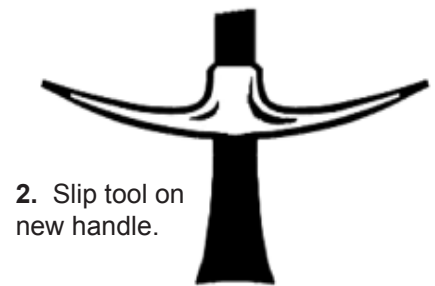
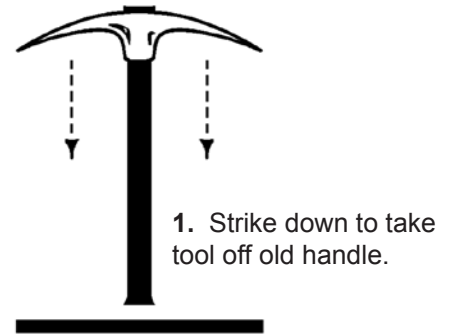

For your safety and convenience:

Wear safety goggles to protect your eyes.

Bring old tool to store to measure for replacement handle.

Forks with D-grip handles

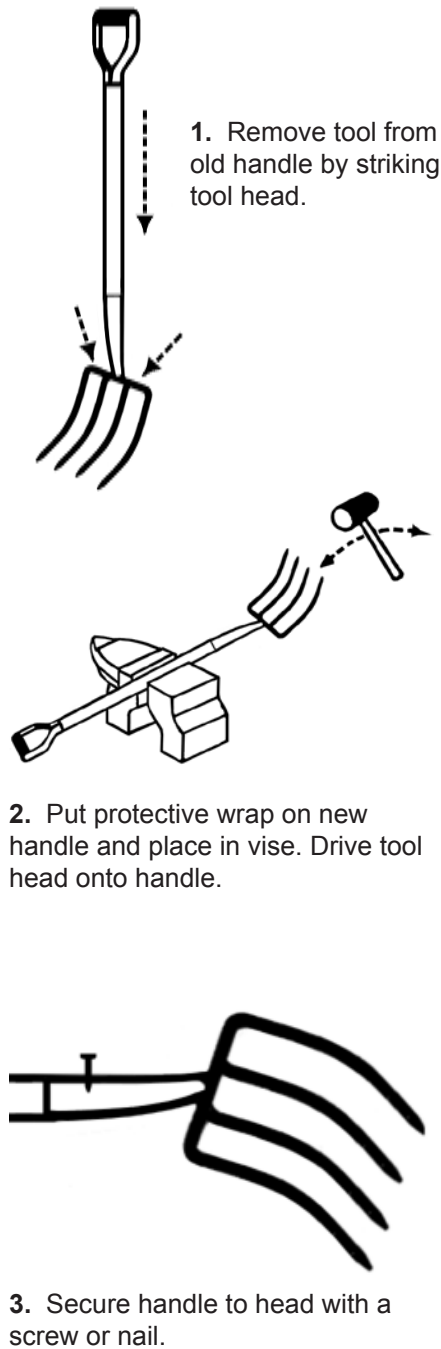

Hoe, rake, & fork handles

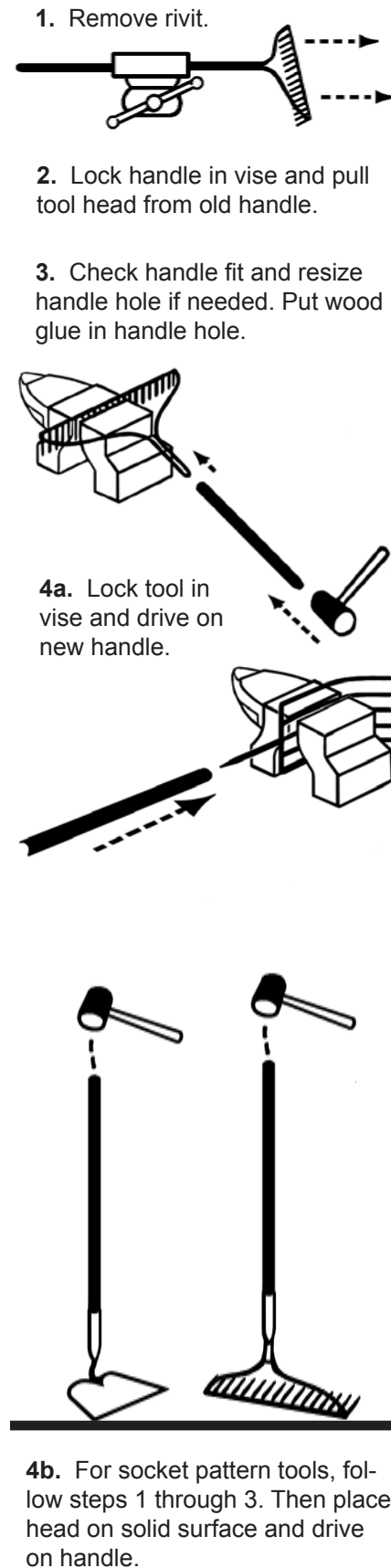

Shovel & spade handles

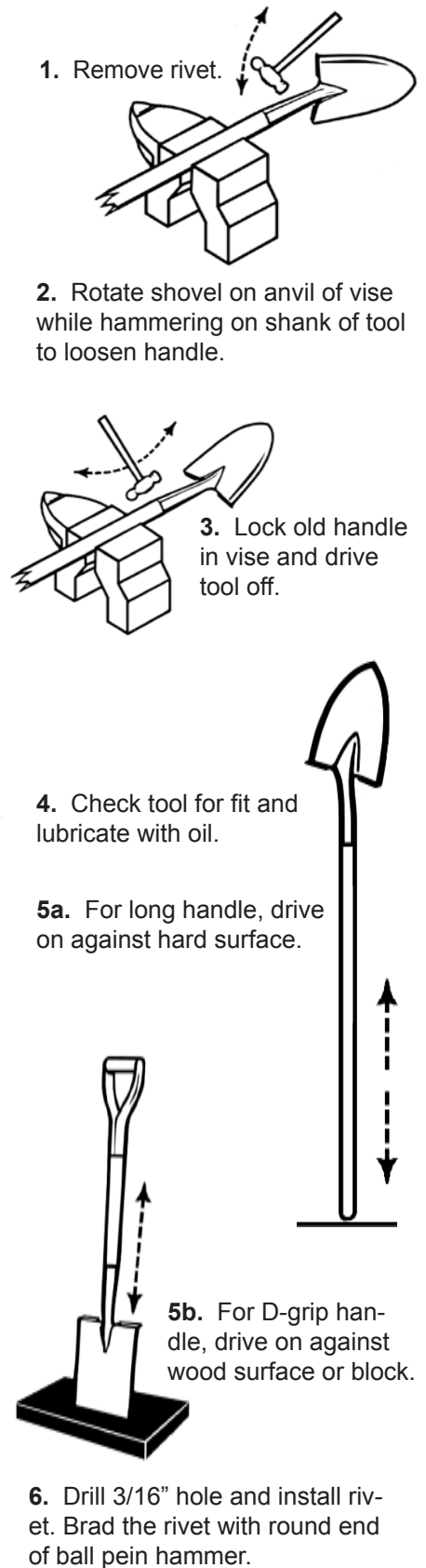

There is no substitute for a good display

- Silent salesmen that sell hard 24/7.
- Illustrated display banner shows and tells which tools each handle fits.
- Simple plan makes every clerk an instant replacement handle expert.
- Makes selection easy for customers.
- Requires minimum space.
- Organized and neat.
- Strong and attractive.
- Available in 5, 8, and 12 hook models.
- Available in wall or floor versions.
- Easily customized to your exact needs.
- Improves inventory control.
- Simplifies re-orders.
- Increases sales profits.



The wall mount displays can be used as floor displays by using the floor stands (ordered separately).

Model	Description
LINK5HD	5-hook display, pegboard wall mount, 15" wide
LINK8HD	8-hook display, pegboard wall mount, 24" wide
LINK12HD	12-hook display, pegboard wall mount, 24" wide
LINKFSD	Floor stand for wall mount displays

Pallet merchandisers



Colorful floor displays can double or triple your inventory turns by attracting customer attention and using space efficiently. Great for end caps, sidewalk displays, and seasonal merchandise.

No set up required. They come fully loaded with a removable protective outer wrap. They are attached to wooden pallets for ease of handling.

Many options are available with a variety of long handle tool assortments. Custom tool combinations and private label are possible.

Full pallet merchandisers are 40" wide and 48" deep.

Half-pallet merchandisers are 40" wide and 24" deep. Fewer tools than full pallets for quick inventory turns.

Quarter pallet merchandisers are 20" wide and 24" deep.

Wood pallet displays are 34" wide and 34" deep.

SEYMOUR

THE WORLD'S BEST TOOLS
STRUCTRON





Merchandising aids attract, inform

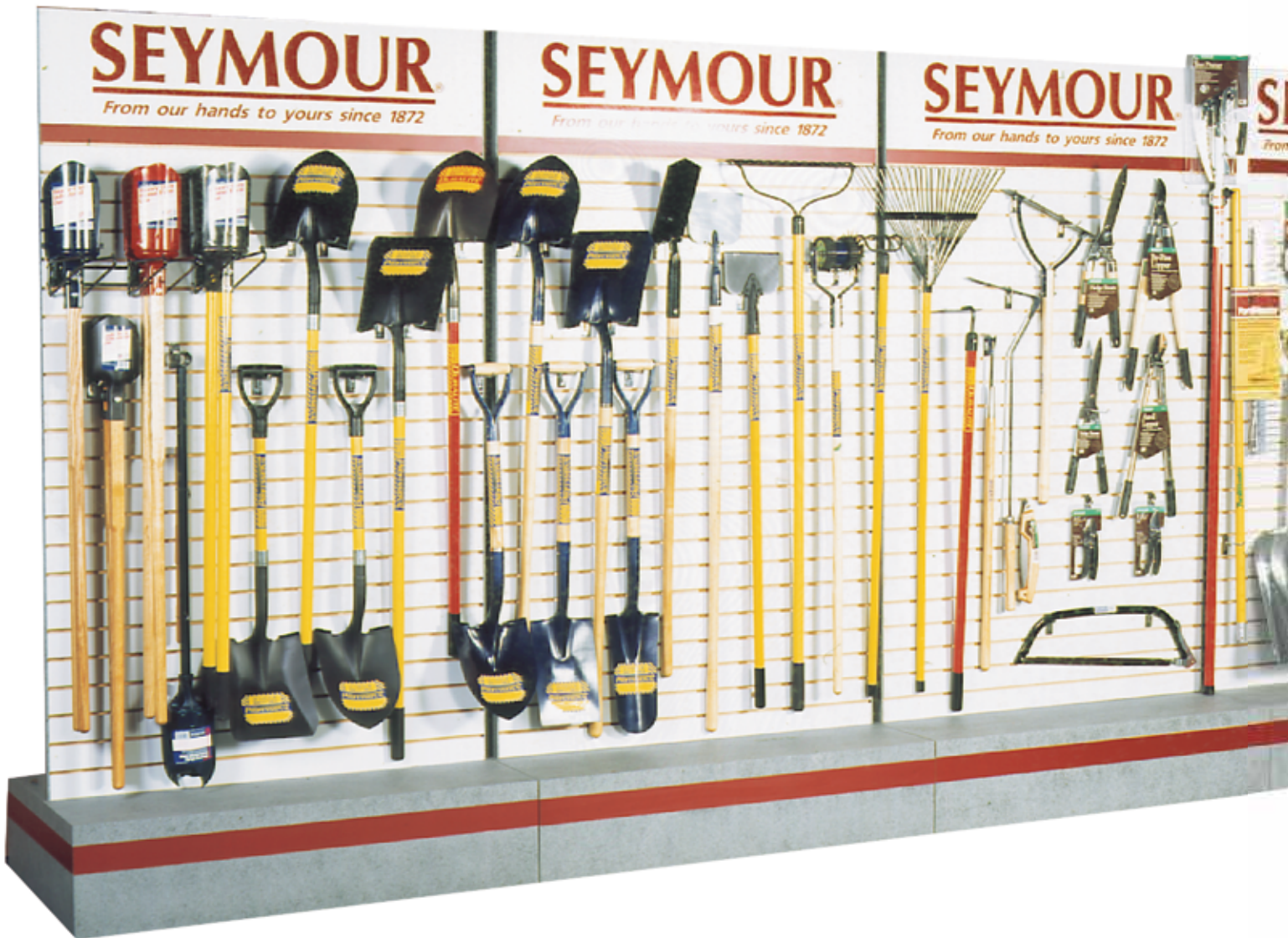

SEYMOUR'S WALL OF FAME

Custom planograms use space efficiently and maximize impact

We custom-design planograms to meet customer needs from filling a narrow niche to completing a wide wall of tools. Careful planning ensures that premium wall space is used for maximum customer impact and sales potential.

Pegboard hangers display products to best advantage

Seymour premium quality pegboard hooks and hangers are custom-designed to display Seymour products to their best advantage.

Seymour Wire Fixtures



PH-2DG Two digger hanger.
Space saving front load design holds 2 post hold diggers.



PH-WF3 Waterfall hanger.
Ideal for long handle tools such as shovels and rakes. Holds 3 tools.



PH-WF6 Waterfall hanger.
Ideal for long handle tools such as shovels and rakes. Holds 6 tools.



PH-PR2 Weeder/pruner holder.
Designed to hold loppers, hedge shears and bow saws horizontally.



SEYMOUR

FOR THE WORLD'S BEST TOOLS
STRUCTRON



SR2

Rolling steel merchandiser

Holds 48 shovels, rakes, and hoes or 24 posthole diggers. Will hold both long handle and D-handle tools. Can be used indoors or outdoors.



SS1

Steel merchandise racks attract customer attention, display tools effectively, and use space efficiently. Versions with wheels can be easily moved indoors or outdoors for product-moving promotions.

STRUCTRON POWER WALL

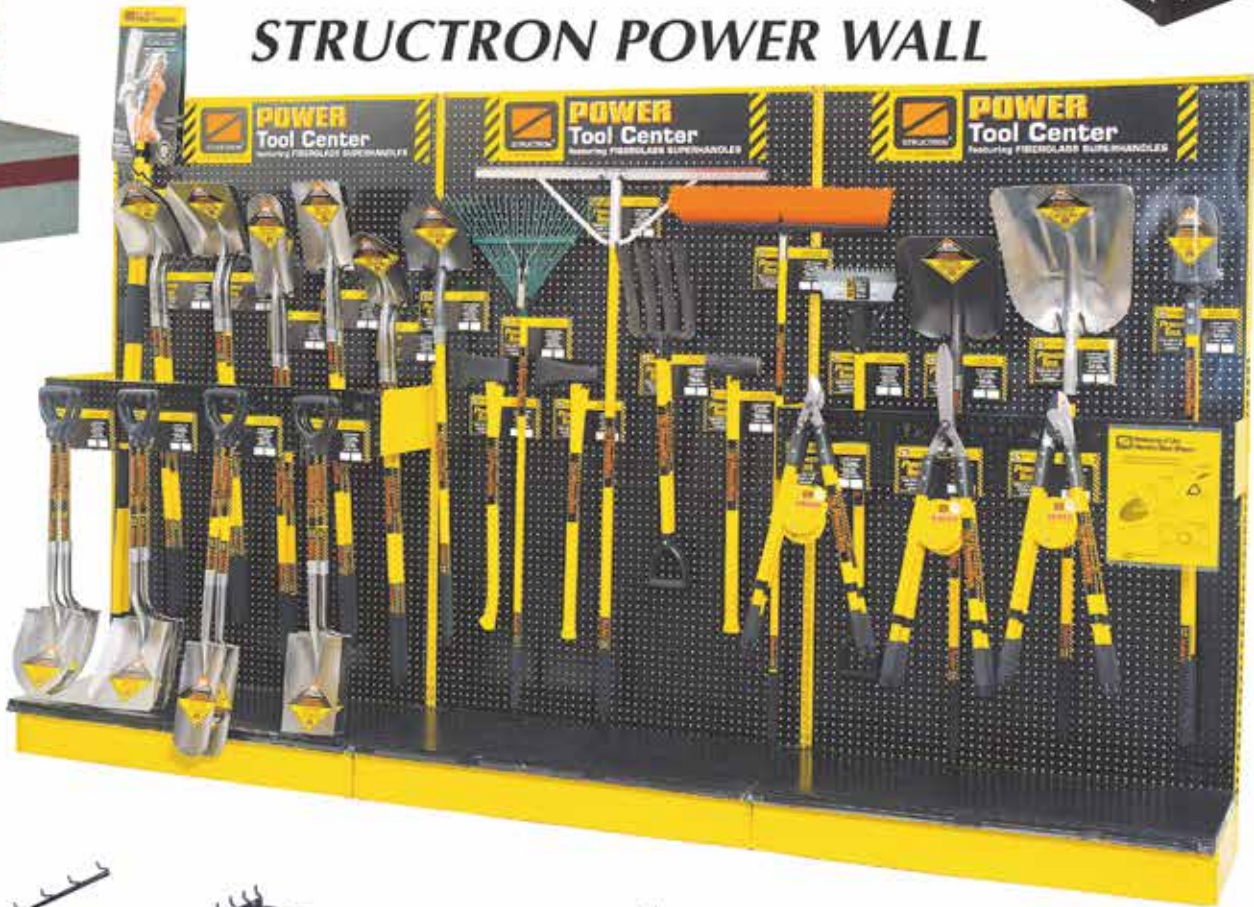

PH-HH Hoe hanger.
Designed specifically for garden hoes and mortar hoes. Also great for bow saws.



PH-11D 11" double hook.
Best hook for D-handle tools.



PH-10S 10" single hook.
Ideal for tools and cards with a single hanging point.



The proof is in the packaging

Informative labels, tags, and packages help your customers make informed choices.

Replacement parts - Complete information and prices for replacement parts for Seymour and Strcutron products are listed in the Seymour Lawn & Garden Tools Price List.



Universal rolling steel merchandiser

This versatile merchandiser can effectively display 40 to 100 tools in a wide variety of combinations. Holds both long handle and D-handle tools. Can be used indoors or outdoors.

Fireplace tools and accessories

Seymour has a complete line of fireplace accessories including firesets, screens, log baskets, grates, rugs, bellows, brooms, fire starters, coal hods, ash buckets, hearth gloves, and other hearth products. To order a fireplace products catalog, call 800-457-1909.



A proven steel merchandiser for fireplace tools and accessories

The Seymour fireplace display is a successful point-of-purchase display for a variety of best-selling fireplace tools and accessories. The all-steel fixture comes complete with shelves, hooks, and a sign. Only 2 feet wide and 9 inches deep. Display is free with purchase of merchandise assortment.



Vinyl bags provide attractive pegboard and slatwall merchandising and customer protection.

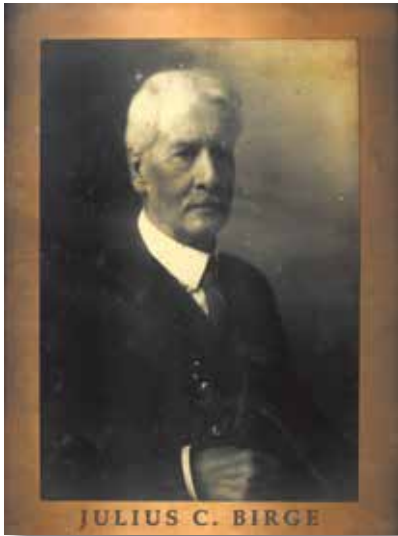

JULIUS C. BIRGE

The Seymour Manufacturing Company of Seymour, Jackson County, Indiana, was organized for manufacturing grain cradles, buggy and wagon wheel spokes and hubs, scythes, and snaths.

The Company began as a corporation in 1872 with principal offices in Wilmington, Delaware; Seymour, Indiana; and St. Louis, Missouri. This organization took place only one year after a group of local businessmen purchased a snath,

grain cradle, and wagon spoke factory that had been operating in the old Indiana State Prison located in Jeffersonville, Indiana. The original group consisted of Julius C. Birge, Walter W. Birge, Ernest N. Birge, Arthur B. Birge, Lynn Faulkconer (whom later built the Lynn Hotel), Charlton A. Swope (whom donated the Art Gallery to the library building), and William M. Ayer.

Julius C. Birge (seen above), of St. Louis, Missouri, who headed the group of local businessmen, purchased stock in the local corporation to diversify his services in the West. After several years of operation, Julius assumed control of the company through stock purchases, and the local industry has been in the hands of the Birge family since that time.

The Company expanded its operation through the years, at first continuing the manufacture of snaths, grain cradles, and wagon spokes, but in the early part of the 20th Century, the Hall Manufacturing Company of northern Indiana was purchased which added posthole diggers and earth augers to a growing line of products.

In 1922, the Company purchased the Dunn Edge Tool Company of Oakland, Maine, and moved that operation to Seymour, Indiana. Shortly after this move, Stanley J. Birge, the son of the founder, joined the Company. A year later, the North Indianapolis Cradle Works was purchased and was moved to Seymour, Indiana.

In 1940, during the years of World War II, Seymour Manufacturing again expanded its production capabilities by adding hog rings and ringers, barnyard tools and other agricultural tools to its offerings that the public demanded. To help with the war effort, Seymour Manufacturing produced starter cartridges for airplanes, and magazines for small arms and wooden wheelbarrows that required minimal metal for assembly.

During the next few decades, the Company continued to expand products and facilities to include cattle dehorners, a snow sled for children called the "Flying Cloud" and other digging tools. The Company also began shipping product to all parts of the United States, Canada, and many foreign countries, which continues today.

In 1956, the Company started its fireplace accessory business with the addition of the "Seymour Classic" fire set that is still manufactured with the same quality and good old-fashioned craftsmanship, for which the Company has become famous. During the next thirty years, the Company continued to acquire other tool manufacturers and continued expanding the operational facilities.

In 1995, Seymour Manufacturing Company acquired the **Structron Corporation** of San Marcos, California. Structron is the premier manufacturer of pultruded fiberglass composite plastics. Although the Structron Corporation produced many different profiles for customers around the world, it is perhaps best known for manufacturing handles for stronger, lighter-weight, and more durable hand tools

In 2004, Seymour Manufacturing Company acquired the **O.P. Link Corporation**, which included the O.P. Link Company of Salem, Indiana, the Sequatchie Handle Works of Sequatchie, Tennessee, the Bruner-Ivory Company of Hope, Arkansas, and the Turner-Day Handle Company of Crossville, Tennessee.

For over one hundred forty years, Seymour Manufacturing Company has continued to add new products and product lines until today; with over 3000 different products available for shipment, the Seymour Manufacturing Companies are able to offer World-Class service to thousands of customers worldwide.

In 2012, Seymour Manufacturing Company was purchased by Midwest Rake Company LLC, a family-owned and also Indiana based manufacturer of specialty tools serving a variety of markets worldwide. Midwest Rake products are sold under the Midwest Rake®, Kenyon, Northstar and Toolite® labels. Midwest Rake is also known for its OEM and private label capabilities. The combined breadth and diversity of the Seymour and Midwest Rake product lines will afford customers of both companies many new and meaningful opportunities going forward.



LINK HANDLES **SEYMOUR**[®] **STRUCTRON**[®] SUPERIOR HEAVY-DUTY TOOLS
A MIDWEST RAKE COMPANY
www.seymourmfg.com

UTILITY GRADE TOOLS
VALUE★PLUS[®]
Lady Floral[®]

HOMEOWNER GRADE TOOLS
DURALITE[®]
SUPERHANDLE[®]
STÅ-LOK[®] LokBlok[®]



SUPER SHOVEL[®]
FIRE BLOX[™]

SUPER SCRAPER[™]
BLIZZARD BUSTER[®]

Seymour Manufacturing Co., Inc.